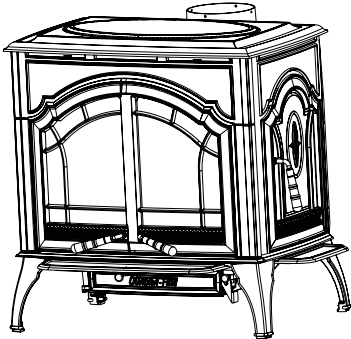


# QUADRA-FIRE®

## Cumberland Gap Non-Catalytic, Front/Side Load, Wood Heater



### Owner's Manual Installation and Operation

#### Models:

**CUMBGAP-MBK**  
**CUMBGAP-PMH**

Tested and  
Listed by  Portland  
Oregon USA  
OMNI-Test Laboratories, Inc.

### CAUTION



#### DO NOT DISCARD THIS MANUAL

- Important operating and maintenance instructions included.
- Read, understand and follow these instructions for safe installation and operation.
- Leave this manual with party responsible for use and operation.



### ⚠ WARNING



**If the information in these instructions is not followed exactly, a fire may result causing property damage, personal injury, or death.**

- Do not store or use gasoline or other flammable vapors and liquids in the vicinity of this or any other appliance.
- Do not overfire - If heater or chimney connector glows, you are overfiring. Overfiring will void your warranty.
- Comply with all minimum clearances to combustibles as specified. Failure to comply may cause house fire.

### ⚠ WARNING



#### HOT SURFACES!

Glass and other surfaces are hot during operation AND cool down.

#### Hot glass will cause burns.

- Do not touch glass until it is cooled
- NEVER allow children to touch glass
- Keep children away
- CAREFULLY SUPERVISE children in same room as fireplace.
- Alert children and adults to hazards of high temperatures.

#### High temperatures may ignite clothing or other flammable materials.

- Keep clothing, furniture, draperies and other flammable materials away.



Installation and service of this appliance should be performed by qualified personnel. Hearth & Home Technologies recommends NFI certified professionals, or technicians supervised by an NFI certified professional.



### ⚠ WARNING



#### Fire Risk.

For use with solid wood fuel only.  
Other fuels may overfire and generate poisonous gases (i.e. carbon monoxide).

# Congratulations

## and Welcome to the Quadra-Fire Family!

Hearth & Home Technologies welcomes you to our tradition of excellence! In choosing a Quadra-Fire appliance, you have our assurance of commitment to quality, durability, and performance.


This commitment begins with our research of the market, including 'Voice of the Customer' contacts, ensuring we make products that will satisfy your needs. Our Research and Development facility then employs the world's most advanced technology to achieve the optimum operation of our stoves, inserts and fireplaces. And

yet we are old-fashioned when it comes to craftsmanship. Each unit is meticulously fabricated and surfaces are hand-finished for lasting beauty and enjoyment. Our pledge to quality is completed as each model undergoes a quality control inspection.


We wish you and your family many years of enjoyment in the warmth and comfort of your hearth appliance. Thank you for choosing Quadra-Fire.

**NOTE: Clearances may only be reduced by means approved by the regulatory authority having jurisdiction**

**LABEL IS LOCATED ON THE BACK OF THE STOVE**



**CAUTION:** HOT WHILE IN OPERATION DO NOT TOUCH, KEEP CHILDREN AND CLOTHING AWAY. CONTACT MAY CAUSE SKIN BURNS. KEEP FURNISHINGS AND OTHER COMBUSTIBLE MATERIAL FAR AWAY FROM THE APPLIANCE. SEE NAMEPLATE AND INSTRUCTIONS.

Tested and Listed by  Portland Oregon USA  
OMNI-Test Laboratories, Inc.

**QUADRA-FIRE**  
TESTED TO:  
UL 1482, UL737, ULC S627-00.

Cumberland Gap

007 SERIAL NO.

Report: #061-S-55-2

LISTED ROOM HEATER, SOLID FUEL TYPE. ALSO FOR USE IN MOBILE HOMES. (UM) 84-HUD. For Use with Solid Wood Fuel Only

**PREVENT HOUSE FIRES**

Install and use only in accordance with manufacturer's installation and operating instructions. Contact local building or fire officials about restrictions and installation inspections in your area. Do not obstruct the space beneath heater.

**WARNING - For Mobile Homes:** Do not install in a sleeping room. An outside combustion air inlet must be provided and unrestricted while unit is in use. The structural integrity of the mobile home floor, ceiling and walls must be maintained. The stove needs to be properly grounded to the frame of the mobile home. Components required for mobile home installation: Outside Air Kit, Part Number 831-1780.

Refer to manufacturer's instructions and local codes for precautions required for passing chimney through a combustible wall or ceiling and maximum chimney height. Inspect and clean chimney frequently. Under Certain Conditions of Use, Creosote Buildup May Occur Rapidly. Do not connect this unit to a chimney serving another appliance. Optional Components: Optional Blower, Part 831-1701. Electrical Rating: 115 VAC, 1.2 Amps, 60 Hz. Route power cord away from unit. Do not route cord under or in front of appliance.

**DANGER:** Risk of electrical shock. Disconnect power supply before servicing. Replace glass only with 5mm ceramic available from your dealer. Do not use grate or elevate fire. Build wood fire directly on firebrick. Do not overfire - if heater or chimney connector glows, you are overfiring. Operate only with the fuel loading door closed. Open only to add fuel to the fire. Optional Fire Screen Part SCR-7006 can only be used in full vertical installations.

**VENT SPECIFICATIONS:**

**SINGLE WALL:** Six inch (6") (152mm) diameter, minimum 24 MSG black or blued steel connector pipe, with a listed factory-built UL103 HT Class "A" chimney, suitable for use with solid fuels, or a masonry chimney, and the referenced clearances.

**DOUBLE WALL:** Six inch (6") (152mm) diameter, listed double wall air insulated connector pipe with listed factory-built UL103 HT Class "A" chimney, or a masonry chimney, and the referenced clearances.

\*In Canada must comply with Standard CAN/ULC-S629-M87 for the 60 degree Factory-built chimneys.

**MOBILE HOME:** Use double wall pipe by Dura-Vent DVL or Kirk Metalbestos DS or Security DL double wall connector pipe. Must be equipped with a spark arrester. Apply double wall clearances below when installing unit.

**MINIMUM CLEARANCES TO NON-COMBUSTIBLE MATERIALS: In Inches & (Millimeters)**  
NOTE: All "A", "C" and "F" Dimensions are to the inside diameter of the flue collar.

TOP VENT VERTICAL	A	B	C	C2	D1	D2*	E1	E2*	F1	F2*	G	H
Single Wall-USA	13(330)	11.5(292)	27(686)	27(686)	18(457)	18(457)	16.5(419)	16.5(419)	20(508)	20(508)	56.5(1435)	N/A
Single Wall-Canada	13(330)	11.5(292)	27(686)	27(686)	18(457)	18(457)	16.5(419)	18(457)	20(508)	21.5(546)	56.5(1435)	N/A
Double Wall-USA	12(305)	10.5(267)	25(635)	26(660)	15(381)	16(406)	11(279)	16(406)	14(356)	19(483)	56.5(1435)	N/A
Double Wall-Canada	12(305)	10.5(267)	25(635)	28(711)	15(381)	18(457)	11(279)	18(457)	14(356)	21(533)	56.5(1435)	N/A

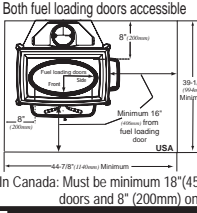
**HORIZONTAL WITH MINIMUM 2 FT (609mm) VERTICAL OFF STOVE TOP**

Single Wall-USA	13.5(343)	12(305)	27(686)	27(686)	17(432)	17(432)	N/A	N/A	N/A	N/A	42.5(1080)	10.5(267)
Single Wall-Canada	13.5(343)	12(305)	27(686)	28(711)	17(432)	18(457)	N/A	N/A	N/A	N/A	42.5(1080)	10.5(267)
Double Wall-USA	11(279)	9.5(241)	27(686)	27(686)	17(432)	17(457)	N/A	N/A	N/A	N/A	39(991)	8(203)
Double Wall-Canada	11(279)	9.5(241)	27(686)	28(686)	17(432)	18(457)	N/A	N/A	N/A	N/A	39(991)	8(203)

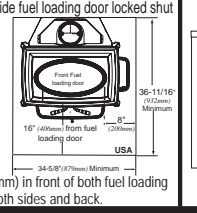
**SEE MANUAL FOR OTHER CONFIGURATIONS**


**FLOOR PROTECTION:** Floor protector must be 1/2" minimum thickness ("k" value = 0.84, R value = 0.59) non-combustible material or equivalent, extending beneath heater and to front/sides/rear as indicated on the diagram. Exception: Non-combustible floor protections must extend beneath the flue pipe when installed with horizontal venting and extend 2" (51mm) beyond each side.

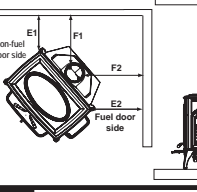
Both fuel loading doors accessible

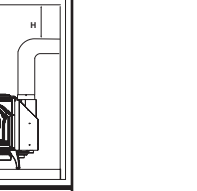



Side fuel loading door locked shut









Mfg by  1445 N. Highway, Colville, WA 99111 www.quadrafire.com

U.S. ENVIRONMENTAL PROTECTION AGENCY - Certified to comply with July 1990 portable fire emission standards 7006-186G

Serial Number

Model Name

Testing Lab & Report Number

Mfg Date

**Safety Alert Key:**

- **DANGER!** Indicates a hazardous situation which, if not avoided will result in death or serious injury.
- **WARNING!** Indicates a hazardous situation which, if not avoided could result in death or serious injury.
- **CAUTION!** Indicates a hazardous situation which, if not avoided, could result in minor or moderate injury.
- **NOTICE:** Indicates practices which may cause damage to the fireplace or to property.

**TABLE OF CONTENTS**

**Section 1: Listing and Code Approvals**

- A. Appliance Certifications .....4
- B. Mobile Home Approved .....4
- C. Glass Specifications.....4
- D. BTU & Efficiency Specifications.....4

**Section 2: Getting Started**

- A. Design, Installation & Location Considerations.....5
- B. Fire Safety .....5
- C. Negative Pressure .....6
- D. Flue Draft Considerations .....7
- E. Venting Systems.....7
- F. Tools and Supplies Needed.....7
- G. Inspect Appliance & Components and Pre-Burn Check List.....7
- H. Typical Stove System .....8

**Section 3: Dimensions & Clearances**

- A. Appliance Dimensions .....9
- B. Clearances to Combustibles .....10

**Section 4: Installation Consideration**

- A. Hearth Requirements .....11-12
- B. Calculating Alternate Floor Protection Material.....12
- C. Reversible Flue Collar & Horizontal Flue Heat Shield.....13
- D. Baffle Diverter.....14-15
- E. Leg Leveling System .....16
- F. Side Fuel Loading Door Locking Mechanism .....16
- G. Outside Air.....17
- H. Optional Blower Installation .....17

**Section 5: Chimney Requirements**

- A. Venting Components .....18
- B. Chimney Systems .....18-21
- C. Installing Chimney Components .....21
- D. Chimney Termination Requirements ..22
- E. 2-10-3 Rule.....22

**Section 6: Mobile Home .....23**

**Section 7: Appliance Set-Up**

- A. Door Handle Assembly .....24
- B. Blower Speed Adjustment .....24

**Section 8: Operating Instructions**

- A. Overfiring Your Appliance .....25
- B. Wood Selection & Storage .....25-26
- C. Burning Process.....26-27
- D. Combustible / Non-Combustible Materials .....27
- E. Air Controls .....27
- F. Heat Output Settings.....28
- G. Burn Rates .....28
- H. Building A Fire.....28
- I. Blower Operating Instructions .....29
- J. Opacity (Smoke) .....29
- K. Clear Space .....30
- L. Frequently Asked Questions .....30
- M. Correct Baffle & Blanket Position .....31

**Section 9: Maintaining & Servicing Appliance**

- A. General Maintenance & Cleaning .....32-33
- B. Appliance Inspection - Routine .....34
- C. Firebrick Inspection & Replacement ...34
- D. Glass Replacement.....34
- E. Baffle Removal & Installation .....35
- F. Quick Reference Maintenance Guide .36

**Section 10: Troubleshooting .....37**

**Section 11: Reference Material**

- A. Exploded Drawings.....38
- B. Service Parts & Accessories.....39-41
- C. Warranty Policy.....42-43
- D. Contact Information.....44

# 1

## Listing and Code Approvals

### A. Appliance Certification

<b>Model:</b>	Cumberland Gap
<b>Laboratory:</b>	OMNI Test Laboratories, Inc.
<b>Report No &amp; Date:</b>	061-S-55-2
<b>Type:</b>	Listed Room Heater, Solid Fuel Type
<b>Standard:</b>	UL1482, UL737, ULC S627-00 and (UM) 84-HUD, Mobile Home Approved.

**NOTE:** This installation must conform with local codes. In the absence of local codes you must comply with the UL1482, UL737, (UM) 84-HUD and NPFA211 in the U.S.A. and the ULC S627-00 and CAN/CSA-B365 Installation Codes in Canada.

The Quadra-Fire Yosemite Wood Stove meets the U.S. Environmental Protection Agency's 1990 particulate emission standards.

### B. Mobile Home Approved

- This appliance is approved for mobile home installations when not installed in a sleeping room and when an outside combustion air inlet is provided.
- The structural integrity of the mobile home floor, ceiling, and walls must be maintained.
- The appliance must be properly grounded to the frame of the mobile home with #8 copper ground wire, and use only listed double-wall connector pipe.
- Outside Air Kit, part 831-1780 must be installed in a mobile home installation.


### C. Glass Specifications

This stove is equipped with 5mm ceramic glass. Replace glass only with 5mm ceramic glass. Please contact your dealer for replacement glass.

Quadra-Fire is a registered trademark of Hearth & Home Technologies.

### D. BTU & Efficiency Specifications

<b>EPA Certified:</b>	3.44 grams per hour
<b>Efficiency:</b>	79.3%
<b>BTU Output:</b>	11,200 to 44,300
<b>Heating Capacity:</b>	1,940 to 3,350 sq ft depending on climate zone
<b>Vent Size:</b>	6 inches
<b>Firebox Size:</b>	2.39 cubic feet
<b>Max Wood Length:</b>	20 inches
<b>Fuel:</b>	Cord Wood
<b>Shipping Weight:</b>	462 lbs



## WARNING

**Fire Risk.**

Hearth & Home Technologies disclaims any responsibility for, and the warranty will be voided by, the following actions:

- Installation and use of any damaged appliance.
- Modification of the appliance.
- Installation other than as instructed by Hearth & Home Technologies.
- Installation and/or use of any component part not approved by Hearth & Home Technologies.
- Operating appliance without fully assembling all components.
- Operating appliance without legs attached (if supplied with unit).
- Do NOT Overfire - If appliance or chimney connector glows, you are overfiring.

Any such action that may cause a fire hazard.

Improper installation, adjustment, alteration, service or maintenance can cause injury or property damage. For assistance or additional information, consult a qualified installer, service agency or your dealer.

**NOTE:** Hearth & Home Technologies, manufacturer of this appliance, reserves the right to alter its products, their specifications and/or price without notice.

# 2

## Getting Started

### A. Design, Installation & Location Considerations

Consideration must be given to:

- Safety
- Convenience
- Traffic flow
- Chimney and chimney connector required

It is a good idea to plan your installation on paper, using exact measurements for clearances and floor protection, before actually beginning the installation. If you are not using an existing chimney, place the appliance where there will be a clear passage for a factory-built listed chimney through the ceiling and roof.

We recommend that a qualified building inspector and your insurance company representative review your plans before and after installation

If this appliance is in an area where children may be near it is recommended that you purchase a decorative barrier to go in front of the appliance. Remember to always keep children away while it is operating and do not let anyone operate this appliance unless they are familiar with these operating instructions.

<b>CAUTION</b>
<p>Check building codes prior to installation.</p> <ul style="list-style-type: none"> <li>• Installation <b>MUST</b> comply with local, regional, state and national codes and regulations.</li> <li>• Consult insurance carrier, local building, fire officials or authorities having jurisdiction about restrictions, installation inspection, and permits.</li> </ul>



### B. Fire Safety




To provide reasonable fire safety, the following should be given serious consideration:

1. Install at least one smoke detector on each floor of your home to ensure your safety. They should be located away from the heating appliance and close to the sleeping areas. Follow the smoke detector manufacturer's placement and installation instructions, and be sure to maintain regularly.
2. A conveniently located Class A fire extinguisher to contend with small fires resulting from burning embers.
3. A practiced evacuation plan, consisting of at least two escape routes.
4. A plan to deal with a chimney fire as follows:

In the event of a chimney fire:

- a. Evacuate the house immediately
- b. Notify fire department

 <b>WARNING</b>
<div style="display: flex; align-items: center;">  <div> <p><b>Fire Risk.</b></p> <p>Hearth &amp; Home Technologies disclaims any responsibility for, and the warranty will be voided by, the following actions:</p> <ul style="list-style-type: none"> <li>• Installation and use of any damaged appliance.</li> <li>• Modification of the appliance.</li> <li>• Installation other than as instructed by Hearth &amp; Home Technologies.</li> <li>• Installation and/or use of any component part not approved by Hearth &amp; Home Technologies.</li> <li>• Operating appliance without fully assembling all components.</li> <li>• Operating appliance without legs attached (if supplied with unit).</li> <li>• Do NOT Overfire - If appliance or chimney connector glows, you are overfiring.</li> </ul> <p>Any such action that may cause a fire hazard.</p> </div> </div>

 <b>WARNING</b>
<div style="display: flex; align-items: center;">  <div> <p><b>Fire Risk.</b></p> <ul style="list-style-type: none"> <li>• Do not operate appliance before reading and understanding operating instructions.</li> <li>• Failure to operate appliance properly may cause a house fire.</li> </ul> </div> </div> <div style="margin-top: 10px;">  </div>

## C. Negative Pressure

Draft is the pressure difference needed to vent appliances successfully. Considerations for successful draft include:

- Preventing negative pressure
- Location of appliance and chimney

**Negative pressure** results from the imbalance of air available for the stove to operate properly. Causes for this imbalance include:

- Exhaust fans (kitchen, bath) etc.)
- Range hoods
- Combustion air requirements for furnaces, water heaters and other combustion appliances
- Clothes dryers
- Location of return-air vents to furnace or air conditioning
- Imbalances of HVAC air handling system
- Upper level air leaks
  - Recessed lighting
  - Attic hatch opening
  - Duct leaks

To minimize the affects of negative air pressure the following must be considered:

- Install the outside air kit. Install the intake on the side of the house towards prevailing winds during the heating season.
- Ensure adequate outdoor air is supplied for combustion appliances and exhaust equipment.
- Ensure furnace and air conditioning return vents are not located in the immediate vicinity of the appliance,
- Avoid installing the appliance near doors, walkways or small isolated spaces.
- Recessed lighting should be of “sealed can” design; attic hatches weather stripped or sealed; and attic mounted ductwork and air handler joints and seams taped or sealed.

### WARNING

**Asphyxiation Risk.**

- Negative pressure can cause spillage of combustion fumes, soot and carbon monoxide.
- Appliance needs to draft properly for safety.

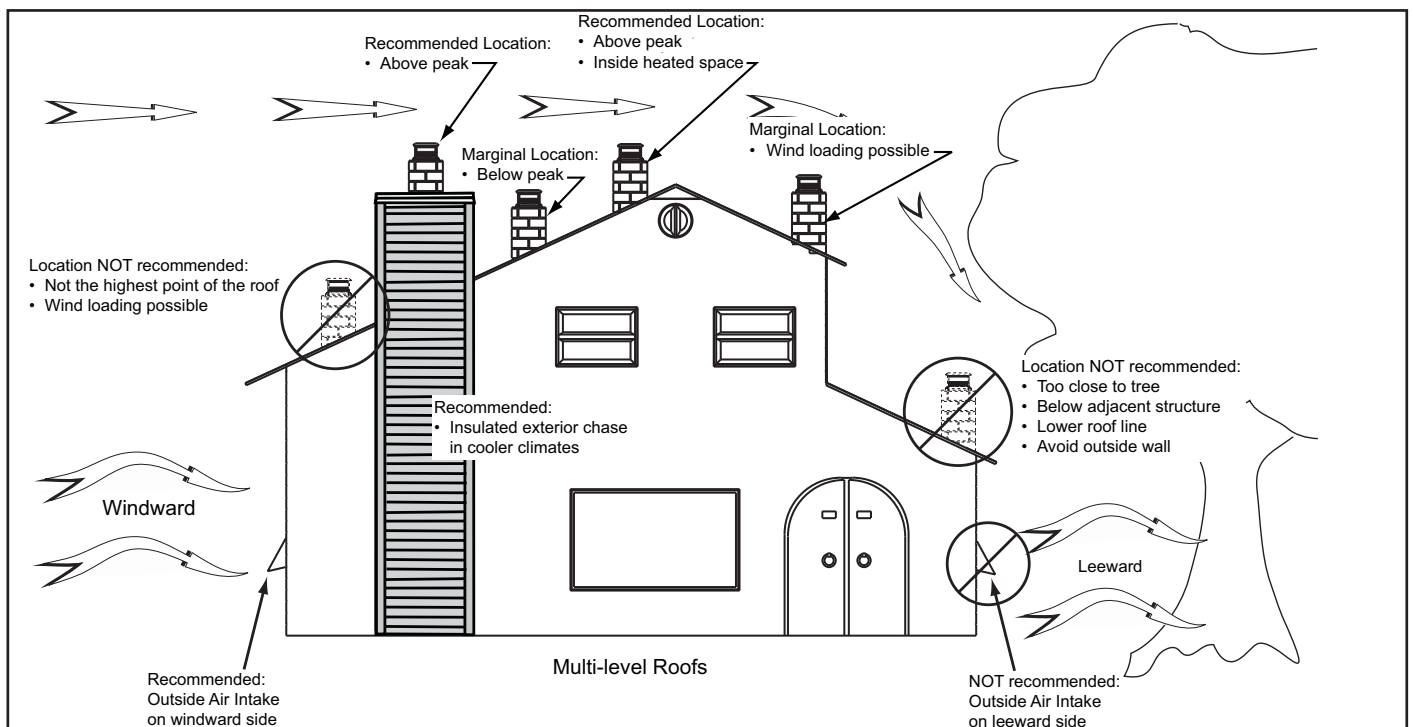


Figure 6.1

**D. Flue Draft Considerations**

Location of the appliance and chimney will affect performance. As shown in **Figure 6.1 on page 6** the chimney should:

- Be installed through the warm space enclosed by the building envelope. This helps to produce more draft, especially during lighting and die down of the fire.
- Penetrate the highest part of the roof. This minimizes the affects of wind turbulence and down drafts.
- Consider the appliance location in order to avoid floor and ceiling attic joists and rafters.



Exterior conditions such as roof line, surrounding trees, prevailing winds and nearby hills can influence stove performance. Your local dealer is the expert in your geographic area and can usually make suggestions or discover solutions that will easily correct your flue problem.

To be sure that your appliance burns properly, the chimney draft (static pressure) should be approximately -.04 inch water column (W.C.) during a low burn and -.10 inch W.C. during a high burn, measured 6 inches (152mm) above the top of the appliance after one hour of operation at each burn setting.

**NOTE:** These are guidelines only, and may vary somewhat for individual installations.

**E. Venting Systems**

The venting system consists of a chimney connector (also known as stove pipe) and a chimney. These get extremely hot during use. Temperatures inside the chimney may exceed 2000°F (1100°C) in the event of a creosote fire. To protect against the possibility of a house fire, the chimney connector and chimney **must be properly installed and maintained**. An approved thimble must be used when a connection is made through a combustible wall to a chimney. A chimney support package must be used when a connection is made through the ceiling to a prefabricated chimney. These accessories are **absolutely necessary** to provide safe clearances to combustible wall and ceiling material. Follow venting manufacturer’s clearances when installing venting system.

	<b>WARNING</b>
	<p><b>Asphyxiation Risk.</b></p> <ul style="list-style-type: none"> <li>• DO NOT CONNECT THIS UNIT TO A CHIMNEY FLUE SERVICING ANOTHER APPLIANCE.</li> <li>• DO NOT CONNECT TO ANY AIR DISTRIBUTION DUCT OR SYSTEM.</li> </ul> <p>May allow flue gases to enter the house.</p>



**F. Tools And Supplies Needed**

Before beginning the installation be sure that the following tools and building supplies are available.

Reciprocating saw	Non-Combustible Sealant Material
Pliers	Gloves
Hammer	Framing Square
Phillips Head Screwdriver	Electric Drill & Bits (1/4")
Flat Blade Screwdriver	Safety Glasses
Plumb Line	1/2 in. - 3/4 in. length, #6 or #8 self drilling screws (need 3 per pipe section connection)
Level	
Tape Measure	
Framing Material	

**G. Inspect Appliance & Components and Pre-Burn Check List**

✓		
1.		Place the appliance in a location near the final installation area and follow the procedures below:
2.		Open the appliance and remove all the parts and articles packed inside the Component Pack. Inspect all the parts and glass for shipping damage. Contact your dealer if any irregularities are noticed.
3.		All safety warnings have been read and followed.
4.		This Owner's Manual has been read.
5.		Floor protection requirements have been met.
6.		Venting is properly installed.
7.		The proper clearances from the appliance and chimney to combustible materials have been met.
8.		The masonry chimney is inspected by a professional and is clean, or the factory built metal chimney is installed according to the manufacturer's instructions and clearances.
9.		The chimney meets the required minimum height.
10.		All labels have been removed from the glass door.
11.		A power outlet is available nearby if installing optional blower assembly.

	<b>WARNING</b>
	<p><b>Fire Risk.</b></p> <p>Inspect appliance and components for damage. Damaged parts may impair safe operation.</p> <ul style="list-style-type: none"> <li>• Do NOT install damaged components.</li> <li>• Do NOT install incomplete components.</li> <li>• Do NOT install substitute components.</li> </ul> <p>Report damaged parts to dealer.</p>

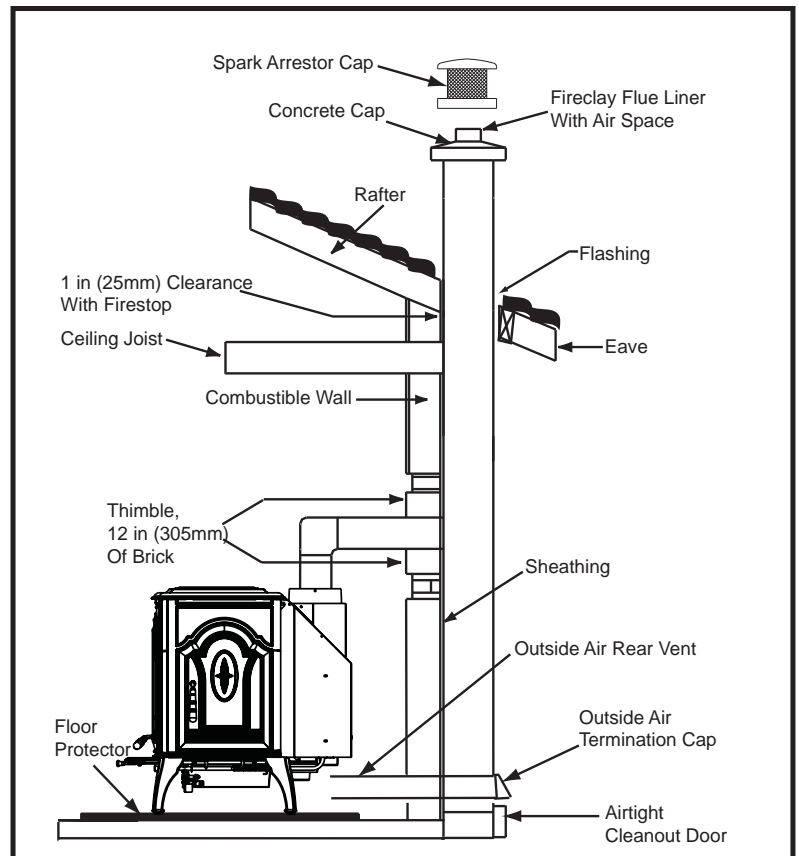
## H. Typical Stove Systems

Stove system with masonry chimney consists of: **Figure 8.1**

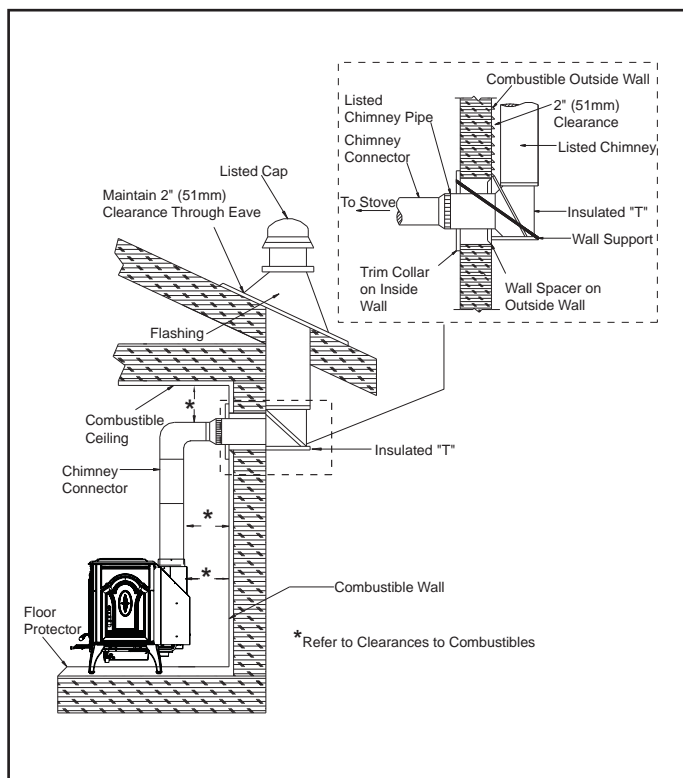
- Stove
- Chimney Connector (stove pipe)
- Thimble
- Masonry Chimney
- Hearth Pad Floor Protection

Stove system with prefabricated metal chimney consists of: **Figures 8.2 and 8.3**

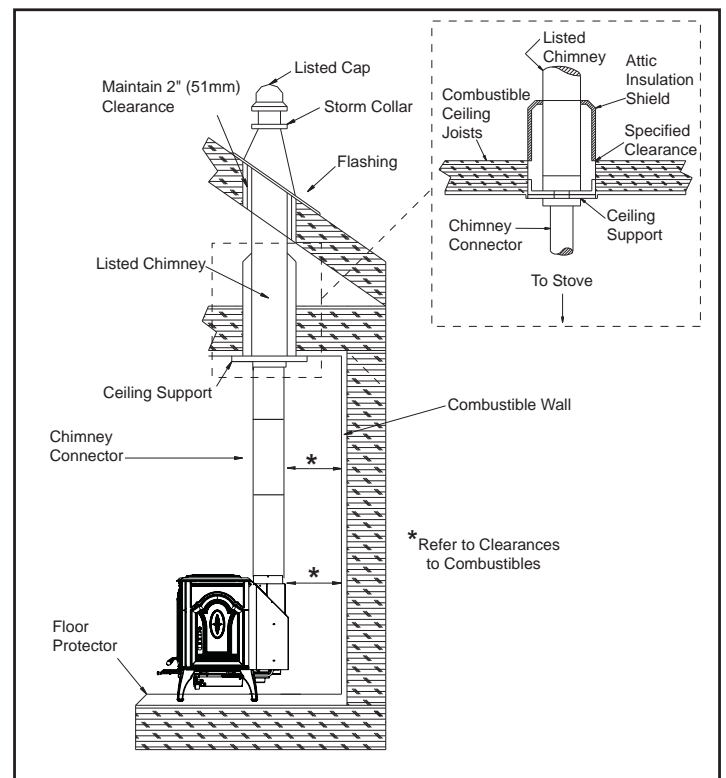
- Stove
- Chimney Connector (stove pipe)
- Thimble (for exterior chimney)
- Firestops
- Insulations Shields
- Storm Collar and Flashing
- Termination Cap
- Hearth Pad Floor Protection



**Figure 8.1 Masonry Chimney**



**Figure 8.2 Exterior Prefabricated Chimney**



**Figure 8.3 Interior Prefabricated Chimney**



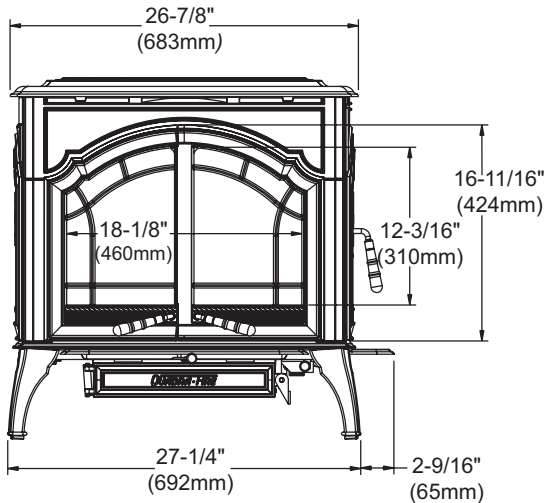
# 3

## Dimensions and Clearances

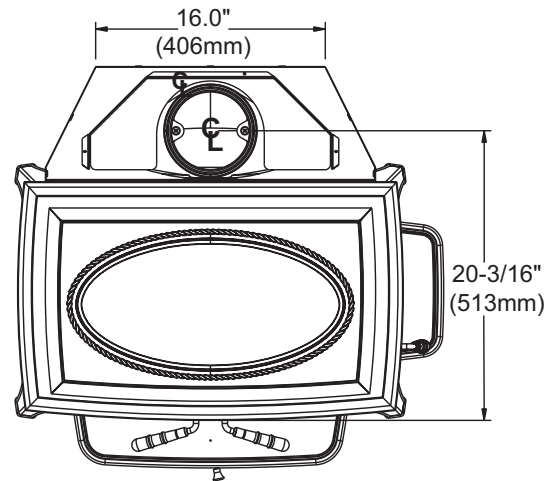
### A. Appliance Dimensions

**NOTE: Flue Collar size is 6 inch (152mm) diameter (ID)**

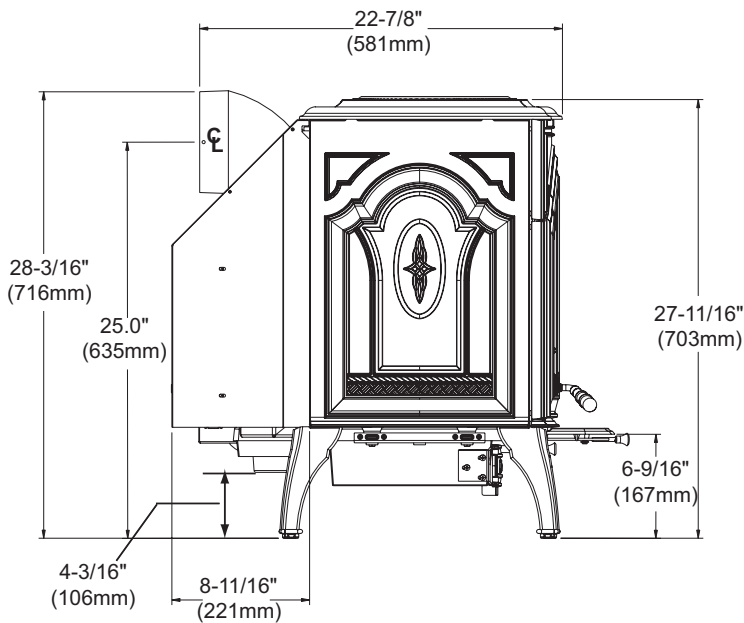
**FRONT VIEW**



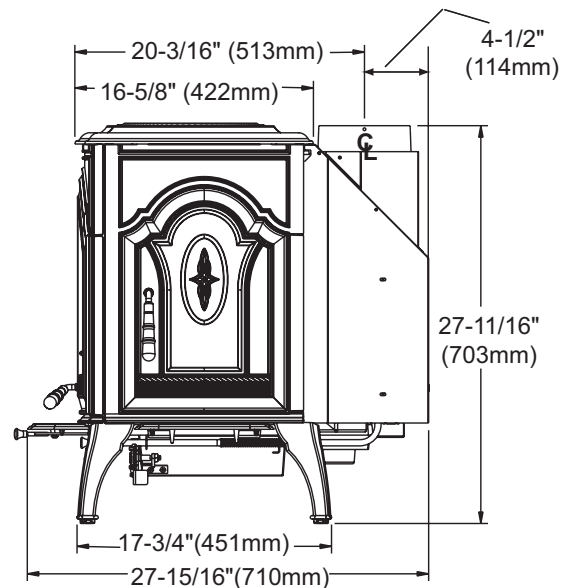
**TOP VIEW**



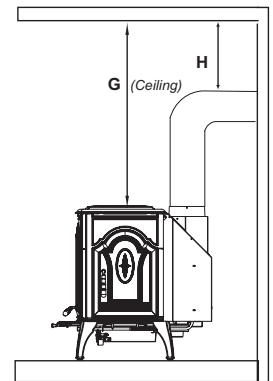
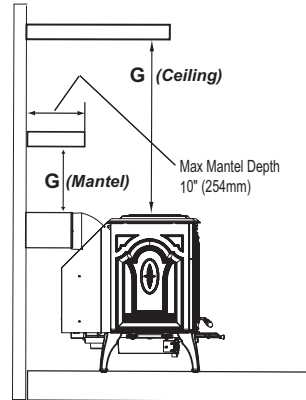
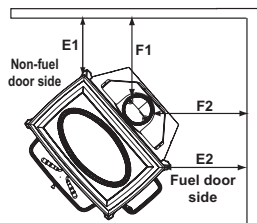
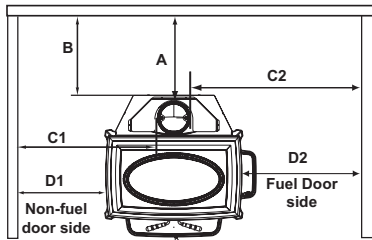
**SIDE VIEW**



**SIDE VIEW WITH FUEL DOOR**



## B. Clearances To Combustibles (UL And ULC)



**IF SIDE FUEL LOADING DOOR IS NOT USED:**

- Must remain in the locked position at all times
- Use clearances for non-fuel side door for both sides

**MINIMUM CLEARANCES TO COMBUSTIBLE MATERIALS: In Inches & (Millimeters)**  
**NOTE: All "A", "C" and "F" Dimensions are to the inside diameter of the flue collar.**

TOP VENT VERTICAL	A	B	C1	C2	D1	D2	E1	E2	F1	F2	G	H
Single Wall-USA	13(330)	11.5(292)	27(686)	27(686)	18(457)	18(457)	16.5(419)	16.5(419)	20(508)	20(508)	56.5(1435)	N/A
Single Wall-Canada	13(330)	11.5(292)	27(686)	27(686)	18(457)	18(457)	16.5(419)	18(457)	20(508)	21.5(546)	56.5(1435)	N/A
Double Wall-USA	12(305)	10.5(267)	25(635)	26(660)	15(381)	16(406)	11(279)	16(406)	14(356)	19(483)	56.5(1435)	N/A
Double Wall-Canada	12(305)	10.5(267)	25(635)	28(711)	15(381)	18(457)	11(279)	18(457)	14(356)	21(533)	56.5(1435)	N/A
<b>HORIZONTAL WITH MINIMUM 2FT (609mm) VERTICAL OFF STOVE TOP. (Note: Horizontal must be with 2ft (609mm) vertical and NOT directly off stove).</b>												
Single Wall-USA	13.5(343)	12(305)	27(686)	27(686)	17(432)	17(432)	N/A	N/A	N/A	N/A	42.5(1080)	10.5(267)
Single Wall-Canada	13.5(343)	12(305)	27(686)	28(711)	17(432)	18(457)	N/A	N/A	N/A	N/A	42.5(1080)	10.5(267)
Double Wall-USA	11(279)	9.5(241)	27(686)	27(686)	17(432)	17(432)	N/A	N/A	N/A	N/A	39(991)	8(203)
Double Wall-Canada	11(279)	9.5(241)	27(686)	28(711)	17(432)	18(457)	N/A	N/A	N/A	N/A	39(991)	8(203)
<b>ALCOVE - Six inch (6") (152mm) diameter listed DOUBLE WALL air insulated connector pipe with UL103 HT listed factory-built Class "A" chimney, or a masonry chimney. (Mobile Home must be equipped with a spark arrestor.)</b>												
							<b>Max Depth</b>	<b>Min Width</b>	<b>Min Height</b>			
							Front Door	48(1219)	55(1397)	72(1829)		
							Side Door-USA	48(1219)	57(1448)	72(1829)		
							Side Door-Canada	48(1219)	61(1549)	72(1829)		
Double Wall-USA	12(305)	10.5(267)	25(635)	26(660)	15(381)	16(406)	N/A	N/A	N/A	N/A	44(1118)	N/A
Double Wall-Canada	12(305)	10.5(267)	25(635)	28(711)	15(381)	18(457)	N/A	N/A	N/A	N/A	44(1118)	N/A
<b>REAR VENT INSTALLATIONS IN A MASONRY FIREPLACE OR THROUGH THE WALL . HORIZONTAL FLUE HEAT SHIELD, PART HTSHLD-7006, REQUIRED ON REAR VENT INSTALLATIONS: Six inch (6") (152mm) diameter listed double wall air insulated connector pipe with UL103 HT listed factory-built Class "A" chimney, or a masonry chimney. (Mobile Home must be equipped with a spark arrestor). Additional specifications include a MAXIMUM 10" (254mm) MANTEL WIDTH and the following clearances.</b>												
Double Wall-USA	N/A	12(305)	27(686)	27(686)	17.5(445)	17.5(445)	N/A	N/A	N/A	N/A	39(991) ceiling	N/A
Double Wall-Canada	N/A	12(305)	27(686)	27.5(699)	17.5(445)	18(457)	N/A	N/A	N/A	N/A	39(991) ceiling	N/A
											<b>USA or Canada -Single or Double Wall Pipe: 31(787) mantel</b>	N/A
											<b>USA or Canada -Single or Double Wall Pipe: 24(610) mantel*</b>	N/A
											<b>*with metal shield spaced 1" (25mm) away from bottom mantel surface</b>	
<b>HEARTH MOUNT - SIDE DOOR MUST BE LOCKED CLOSED</b>												
Single Wall-USA	18(457)	10(254)	22(559)	31(787)	N/A	N/A	N/A	N/A	N/A	N/A	N/A	N/A
Single Wall-Canada	18(457)	10(254)	22(559)	31(787)	N/A	N/A	N/A	N/A	N/A	N/A	N/A	N/A

**NOTE: Optional Fire Screen, Part SCR-7006, can only be used in FULL Vertical installations**

# 4 Installation Considerations

## A. Hearth Protection Requirements

**FLOOR PROTECTOR:** Floor protector must be non-combustible material, extending beneath heater and to the front/sides/rear as indicated. The floor must be a minimum of 1/2 inch (26mm) thickness ("k" value = 0.84, R value = 0.59) non-combustible or otherwise adequately protected from radiant heat given off by the unit and from sparks and falling embers. A layer of thin brick or ceramic tile over a combustible floor is not sufficient. See Alternate Floor Protection on **page 12**.

**In USA installations,** it is necessary to install a non-combustible floor protector at least 16 inches in front and 8 inches to both sides of the fuel loading doors. **See \*exception below.**

**In Canada,** similar floor protection must be provided 18 inches (450mm) in front and 8 inches (200mm) from the sides and rear of the stove. **See \*exception below.**

**\*EXCEPTION:** Non-combustible floor protections must extend beneath the flue pipe when installed with horizontal venting and extend 2 inches (51mm) beyond each side.

### SIDE FUEL DOOR LOCKED SHUT

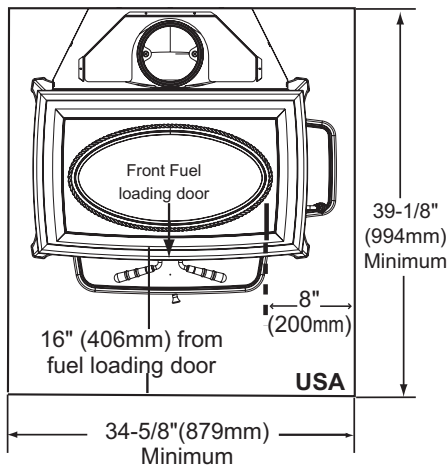


Figure 11.1

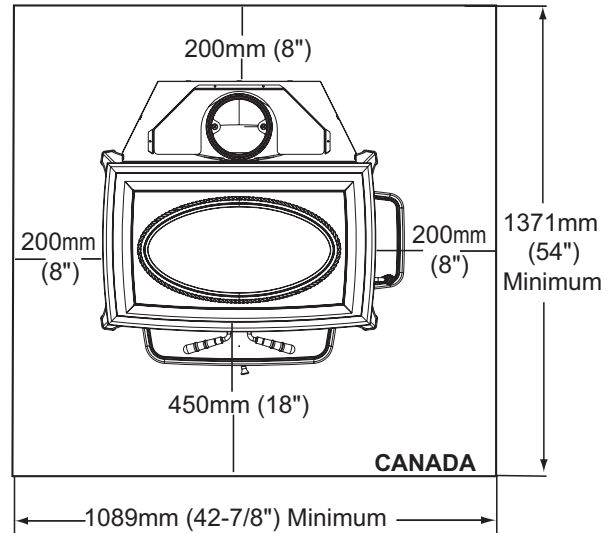


Figure 11.2

### BOTH FUEL DOORS ACCESSIBLE

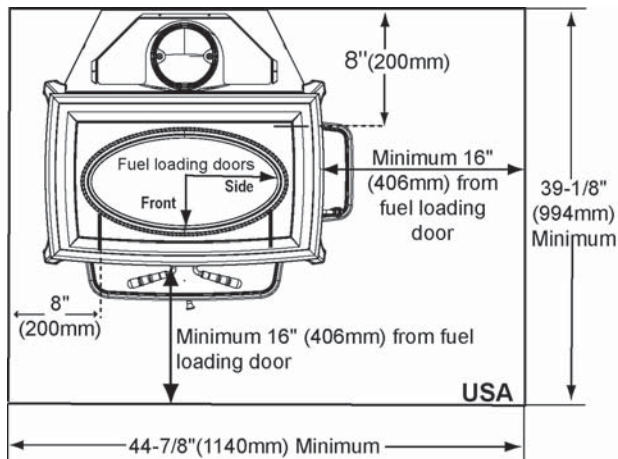


Figure 11.3

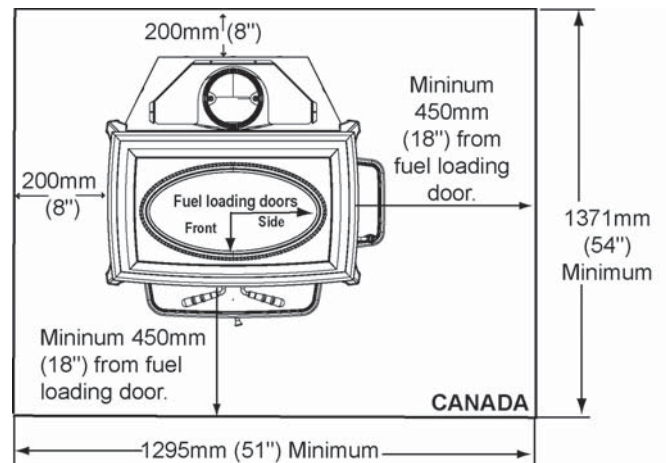


Figure 11.4

**A. Hearth Protection Requirements (Cont'd)**

**SIDE FUEL DOOR LOCKED SHUT - USA ONLY**

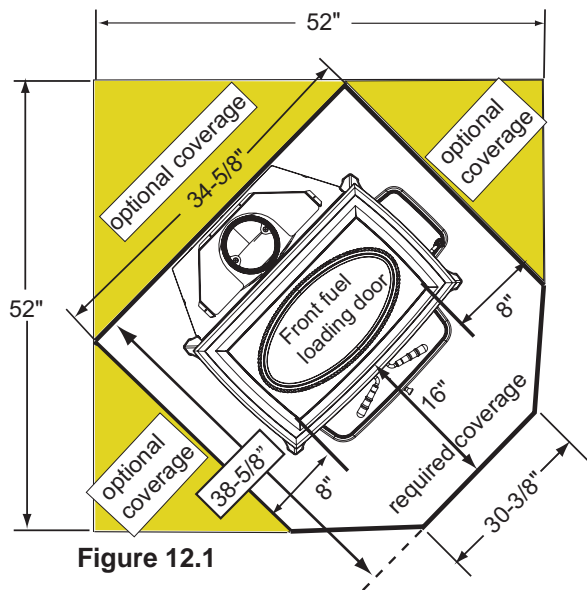


Figure 12.1

**BOTH FUEL DOORS ACCESSIBLE - USA ONLY**

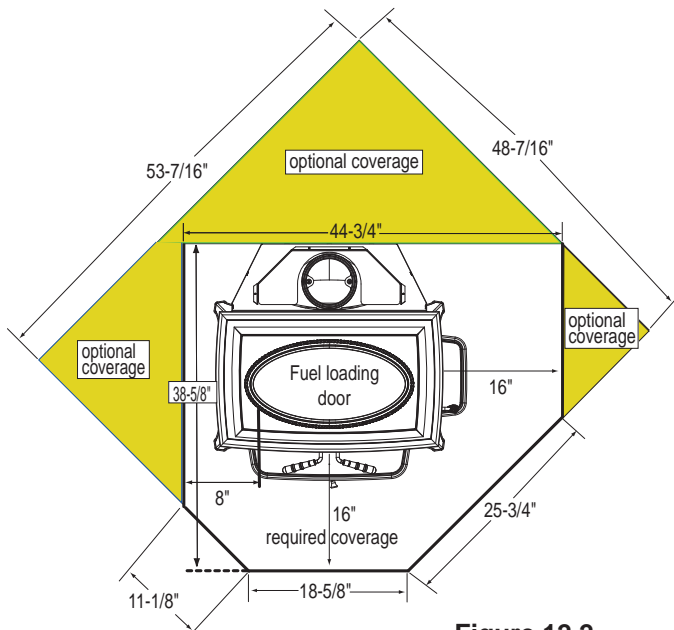


Figure 12.2

**B. Calculating Alternate Floor Protection Material**

**Thermal Conductivity: k value**

The k value indicates the amount of heat (in BTU's) that will flow in 1 hour through 1 square foot of a uniform material 1 inch thick for each degree (F) of temperature difference from one side of the material to the other. The LOWER the k factor means less heat is being conducted through the non-combustible material to the combustible material beneath it. The k value of a material must be equal or smaller then the required k value to be acceptable.

$$\frac{\text{(BTU) (inch)}}{\text{foot}^2 \text{ (hour) } (^\circ\text{F})}$$

**Thermal Resistance: R value**

The R value is a measure of a material's resistance to heat transfer. R value is convenient when more than one material is used since you can add the R values together, whereas you can not do this for k value. The HIGHER the R factor means less heat is being conducted through the non-combustible material to the combustible material beneath it. The R value of a material must be equal or larger then the required R value to be acceptable.

**Converting k to R:**

Divide 1 by k and multiply the results times the thickness in inches of the material.

$$R = 1/k \times \text{inches of thickness}$$

**Converting R to k:**

Divide the inches of thickness by R.

$$k = \text{inches of thickness} / R$$

**Calcalatons:**

Example: Floor protection requires k value of 0.84 and 3/4 inch thick.

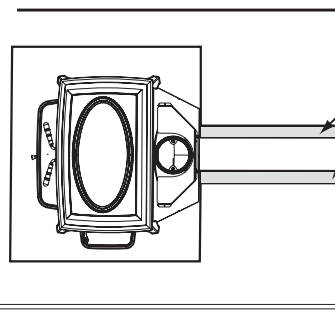
Alternative material has a k value of 0.6 and is 3/4 inch thick.

Divide 0.6 by .75 = k value of 0.80. This k value is smaller than 0.84 and therefore is acceptable.

**HORIZONTAL VENTING**

**NOTE:**

- Illustrations and photos reflect typical installations and are FOR DESIGN PURPOSES ONLY.
- Illustrations/diagrams are not drawn to scale.
- Actual installation may vary due to individual design preference
- Hearth & Home Technologies reserves the right to alter its products.



Floor protection must extend length of flue and 2 inches (51mm) beyond each side of pipe (shaded area)

**USA - Required  
CANADA - Recommended**

**B. Reversible Flue Collar and Horizontal Flue Heat Shield**

**Tools Required:** Phillips head screwdriver; 3/8" and 7/16" wrench

The flue collar is reversible for either a top or rear venting installation. The appliance is shipped with the flue collar in the top vent position.

**REQUIRED PARTS FOR REAR INSTALLATION:**

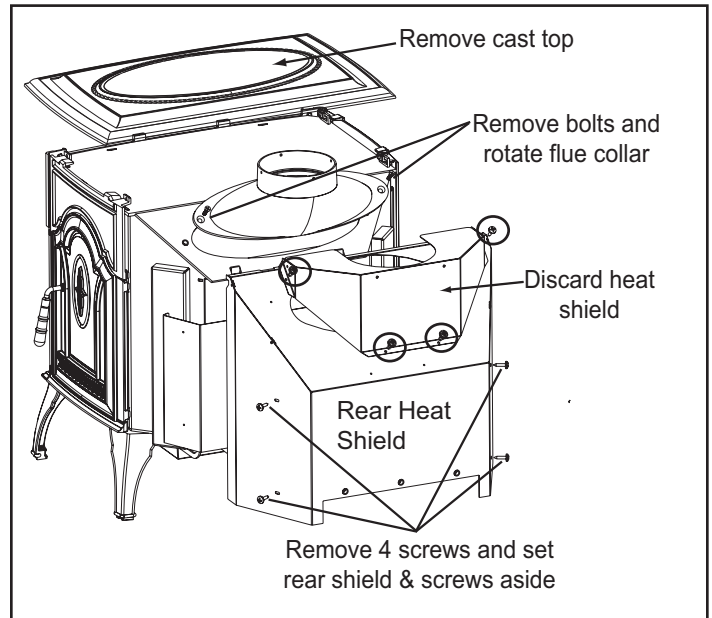
- Baffle Diverter: Shipped with appliance located inside firebox
- Horizontal Flue Heat Shield, Part HTSHLD-7006: Not supplied, must be purchased from your local authorized dealer

**Converting Collar For Rear Vent Installation**

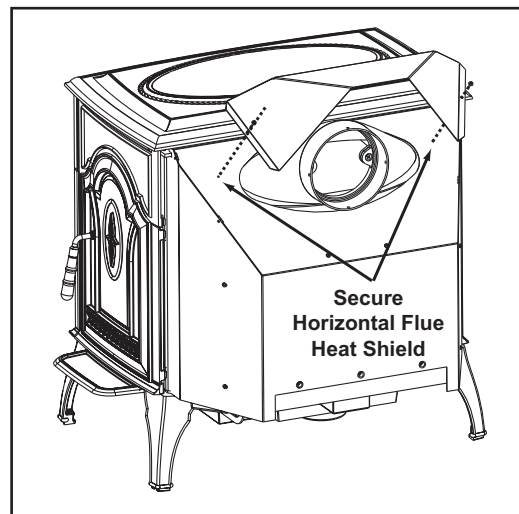
*and*

**Installing Required Horizontal Flue Shield**

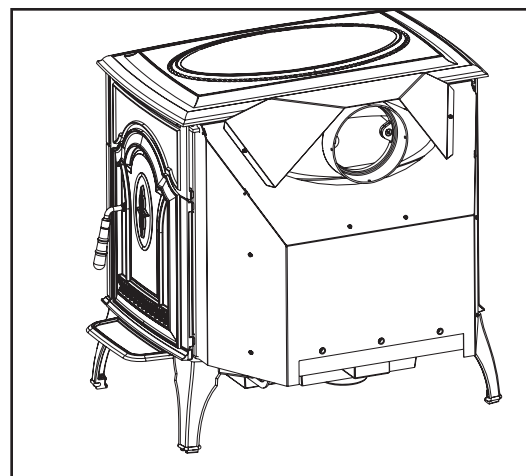
1. Lift off cast top. Remove 4 Phillips head screws from the heat shield. Discard heat shield and save the screws. **Figure 13.1.**
2. Remove 4 Phillips head screws from the rear shield, 2 on each side, lift shield off and set aside. **Figure 13.1.**
3. Remove 1 bolt from each side of the flue collar and retrieve nuts attached to bolts. Use 3/8" and 7/16" wrenches. **Figure 13.1.**
4. Turn vent to horizontal position. Inspect sealant to ensure a leak free application. Re-attach bolts. **Figure 13.1.**
5. Re-attach the rear heat shield.
6. Attach required accessory Horizontal Flue Shield with 2 of the screws removed in Step #1 and secure in place.
7. Follow instructions for placing the Baffle Diverter on **pages 14 & 15.**
8. Place cast top on the unit. See **Figure 13.3** for completed view.



**Figure 13.1**



**Figure 13.2**



**Figure 13.3 - Completed View**

**D. Baffle Diverter**

**REQUIRED ON ALL HORIZONTAL INSTALLATIONS**

**Baffle Diverter:**

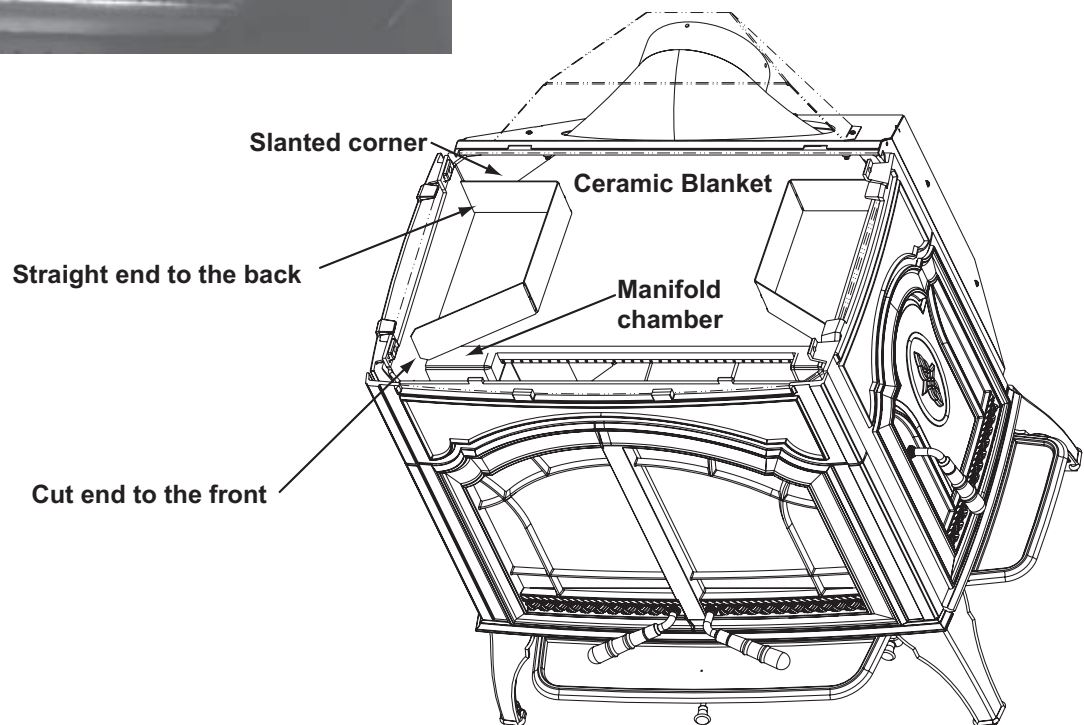
- Packed inside the firebox
- Shipped flat from the factory.
- Use the template on **page 15** to bend the baffle diverter into the proper position.

1. Open both doors.
2. Hold the diverter in a vertical position with the straight edge going in first and then rotate it to the inside of the firebox as you slide the bent diverter over the ceramic blanket . **Figure 14.1.**
3. Place in position as shown in **Figure 14.2** below. The front edge of the diverter will rest on the front edge of the manifold chamber in a flush position. The back edge will butt up against the back slanted corner.
4. Repeat for other side.

	<b>WARNING</b>
	<p><b>Fire Risk.</b>                  Required on all rear horizontal installations.                  Excessive smoke or flame spillage into the room may occur.</p>



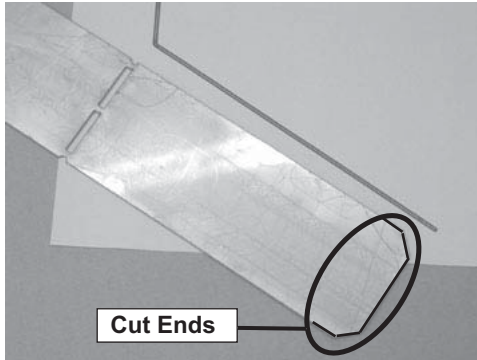
**Figure 14.1**



**Figure 14.2**

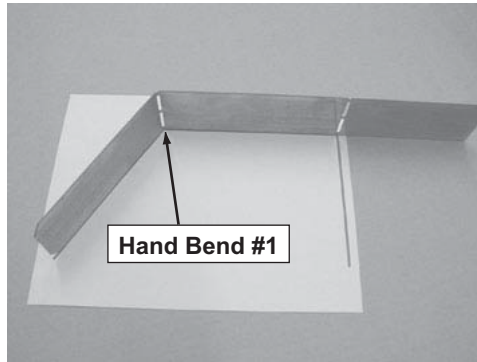
# BENDING TEMPLATE

**STRAIGHT END** 

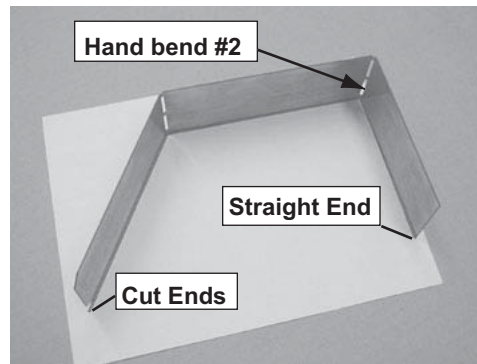


Lay the flat diverter on the template with the cut ends at the bottom of the template.

**Baffle Diverter  
is shipped  
inside firebox.**





**HAND BEND #1**  
Bend the diverter to match the same degree bend as in the template.



**HAND BEND #2**  
Bend the diverter 90° to complete the process.

Place diverter on template to confirm the bends match the template.

**CUT ENDS** 

	<b>WARNING</b>
	<b>Fire Risk.</b> Required on all rear horizontal installations. Excessive smoke or flame spillage into the room may occur.

## E. Leg Leveling System

1. Thread Allen bolts through nuts until flush. **Figure 16.1.**  
The Allen bolts and nuts are included in the component pack inside the appliance firebox.
2. Slide assembled nuts and bolts into slots on legs with the nuts on the bottom. **Figure 16.2.** Use a 5/32 Allen wrench to adjust legs up and down to desired level. **Figure 16.3.**

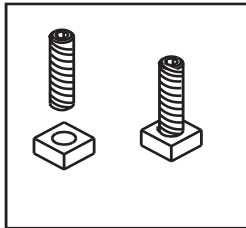


Figure 16.1

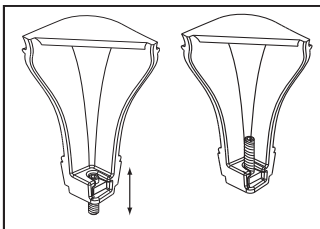


Figure 16.2

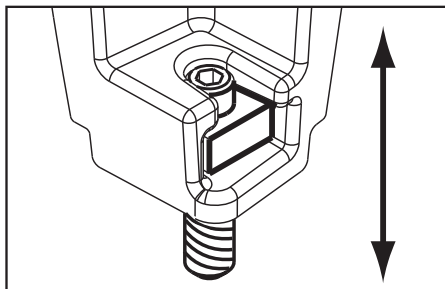


Figure 16.3 - Bolt fully extended

## F. Side Fuel-Loading-Door Locking Mechanism

The side fuel loading door is shipped locked in place. **Figure 16.4**

You must first decide where you are locating your stove and determine if you meet the minimum required clearances from combustibles for loading wood into the firebox from the side door.

If you do not meet the clearances found on **page 10**, leave the door locked in place. If you unlock the door without meeting the minimum required clearances **YOU WILL VOID YOUR WARRANTY AND ASSUME ALL RESPONSIBILITIES.**

If you meet the minimum clearances, follow the instructions to unlock the door.

If in the future you decide to relocate your stove, again determine if you meet the minimum required clearances to combustibles in the new location. If you do not, you are required to lock the door shut and it must remain locked at all times.

### Instructions To Unlock Side Fuel Door

1. Open front door.
2. Using a 5-32 Allen wrench, remove the bolt from the locking bracket. **Figure 16.4.**
3. Save the bracket and bolt for potential future use.

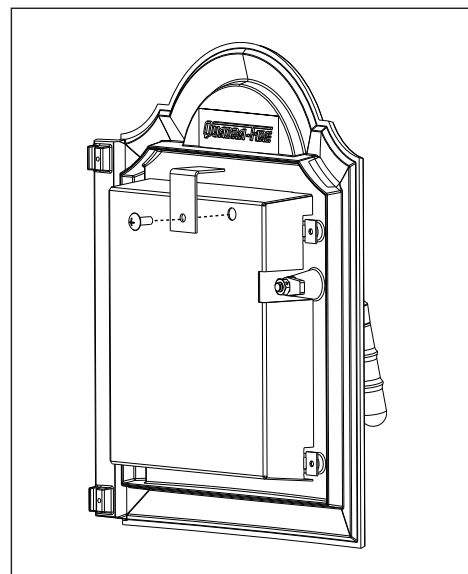


Figure 16.4



**G. Outside Air Kit Installation**

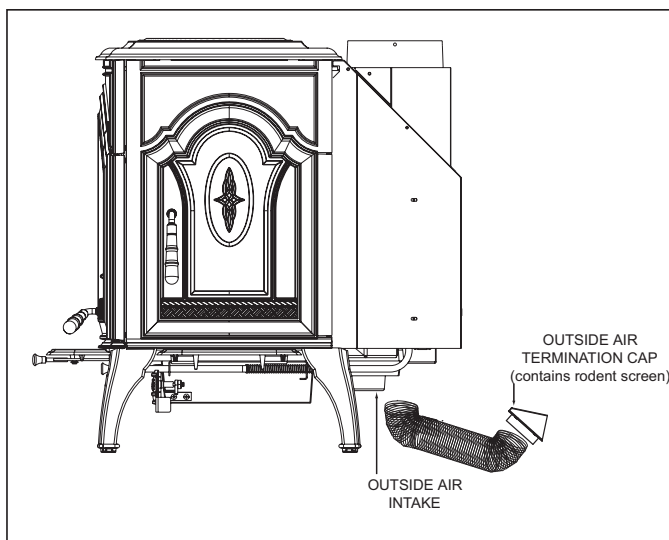
**Included in Kit:** 2 cable ties; outside air termination cap; mounting screws (Discard the remaining parts).

**Items Needed for Installation:** 4 in. (102mm) diameter flex pipe in the length as required for your installation; Phillips screwdriver; Silicone sealant; Drills and saws necessary for cutting holes through the wall or flooring in your home.

1. Remove all materials from packing box.
2. Mount the flex flange (with pipe fitting extending out), over the intake air opening at the rear of stove using the four mounting screws supplied with kit.
3. Cut a 4 inch (102mm) minimum hole in the floor or wall to accommodate outside air piping. Use 4 inch (102mm) metal flex or rigid piping to directly connect outside air to the unit or into **vented** crawl space. **(Do not put flex into a non-vented crawl space).**

If using flex tubing attach cable ties to secure tubing at both ends. Use the supplied termination cap with a rodent screen. Seal between the floor or wall and the pipe with silicone to prevent moisture penetration.

**NOTE:** If you plan to install the optional blower **AND** the outside air kit, complete installation of the outside air kit **FIRST**.

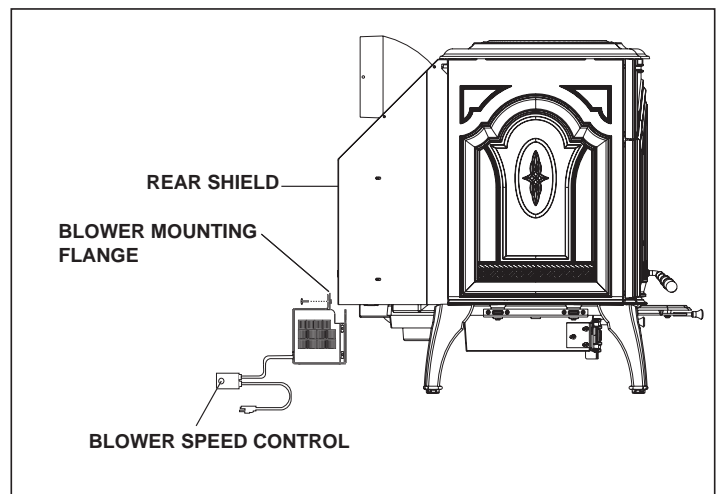


**Figure 17.1**

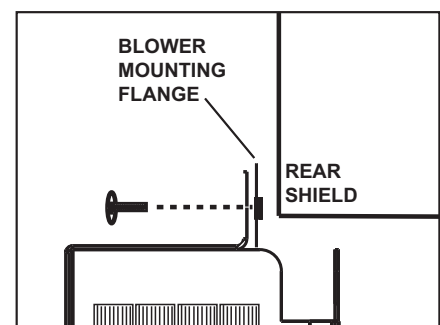
**H. Installation Of Optional Blower**

*The blower is shipped fully assembled and ready for installation.*

1. Remove 3 phillips head screws from rear of stove.
2. Using the phillips head screws, attach blower to lower rear of stove, as shown.
3. Plug blower cord into a grounded outlet. Do not remove ground prong from plug. Route power cord to avoid heat from the stove, or other damage. Do not route cord under or in front of appliance.
4. Adjust the blower speed control to the desired speed.



**Figure 17.2**



**Figure 17.3**

# 5 Chimney Requirements

## A. Venting Components

### Chimney Connector:

It is also known as flue pipe or stove pipe. The chimney connector joins the stove to the chimney. It must be a 6 inch (152mm) minimum diameter 24 gauge mild steel black or 26 gauge blued steel, or an approved air-insulated double wall venting pipe.

### Thimble:

A manufactured or site-constructed device installed in combustible walls through which the chimney connector passes to the chimney. It is intended to keep the walls from igniting. Site constructed thimbles must meet NFPA 211 Standards. Prefabricated must be suitable for use with selected chimney and meet UL103 Type HT Standards. Follow instructions provided by the manufacturer for manufactured thimbles for masonry chimney and prefabricated chimneys.

### Chimney:

The chimney can be new or existing, masonry or prefabricated and must meet the following minimum requirements specified in Section 5B.

## B. Chimney Systems

### Prefabricated Metal Chimney

- Must be minimum 6 inch (152mm) diameter (ID) high temperature chimney listed to UL 103 HT (2100°F) or ULC S629M.
- Must use components required by the manufacturer for installation.
- Must maintain clearances required by the manufacturer for installation.
- Refer to manufacturers instructions for installation.

**NOTE:** In Canada when using a factory-built chimney it must be safety listed, **Type UL103 HT (2100°F) CLASS "A"** or conforming to **CAN/ULC-S629M, STANDARD FOR 650°C FACTORY-BUILT CHIMNEYS.**

### ADDITIONAL REQUIRED PARTS FOR REAR INSTALLATION:

- Baffle Diverter: Shipped with appliance located inside firebox
- Horizontal Flue Heat Shield, Part HTSHLD-7006: Not supplied, must be purchased from your local authorized dealer

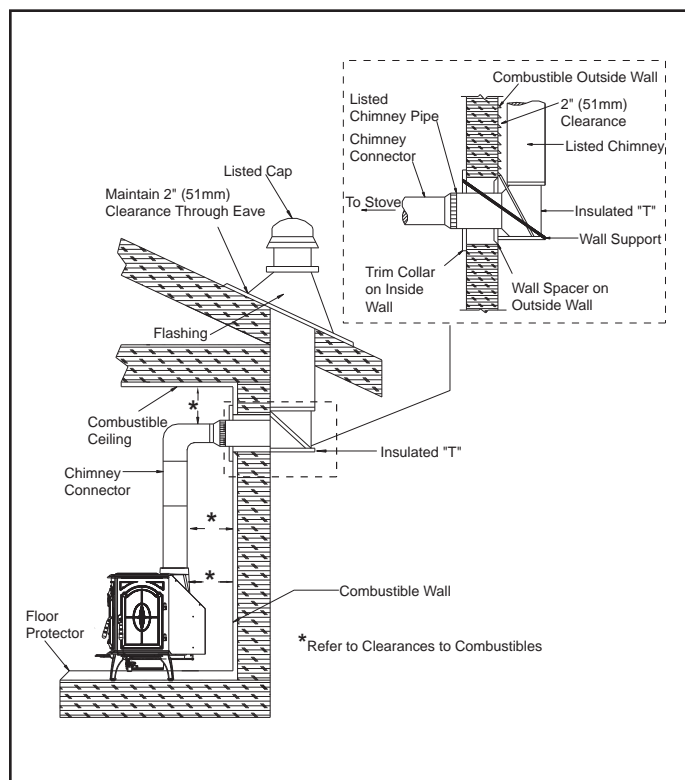


Figure 18.1 Prefabricated Exterior Chimney

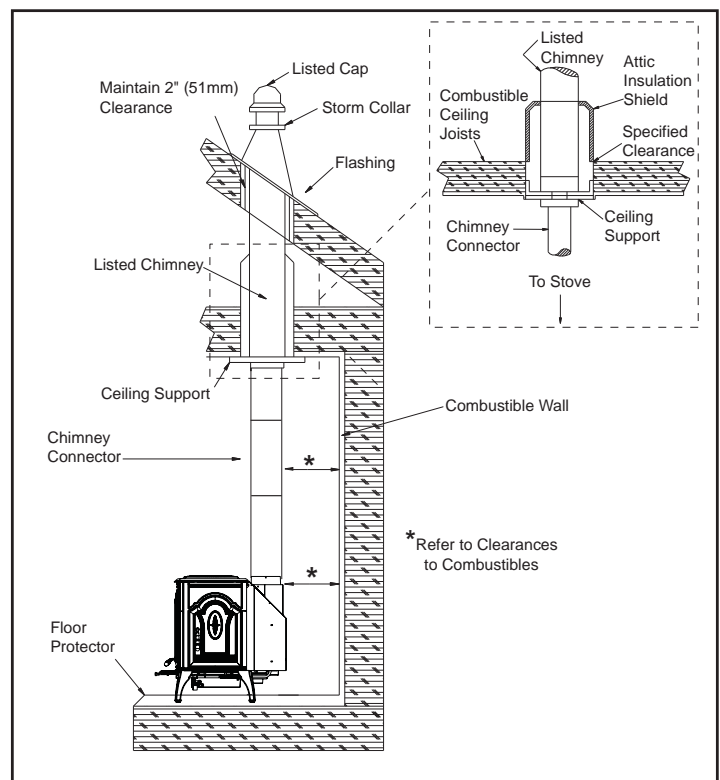


Figure 18.2 - Prefabricated Interior Chimney

**Thimble**

Site constructed for masonry chimney installation:

**Components**

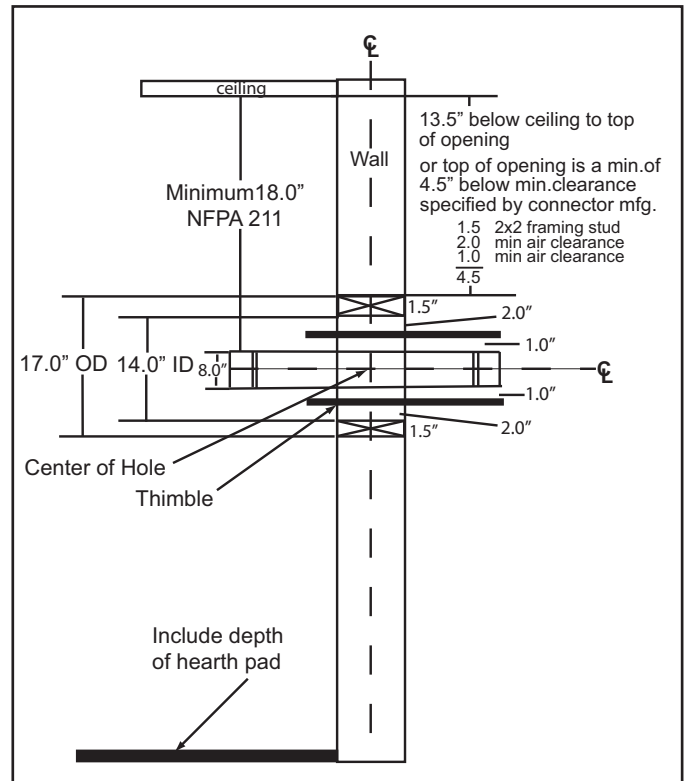
- A minimum length of 12 inches [305mm] (longer for thicker walls) of solid insulated factory-built chimney length constructed to UL 103 Type HT 6 inch (152mm) inside diameter. Chimney needs to extend a minimum of 2 inches (51mm) from the interior wall and a minimum of 1 inch (25mm) from the exterior wall.
- Wall spacer, trim collar and wall band to fit solid pack chimney selected.
- Minimum 8 inch (203mm) diameter clay liner section (if not already present in chimney) and refractory mortar.

**Air Clearances**

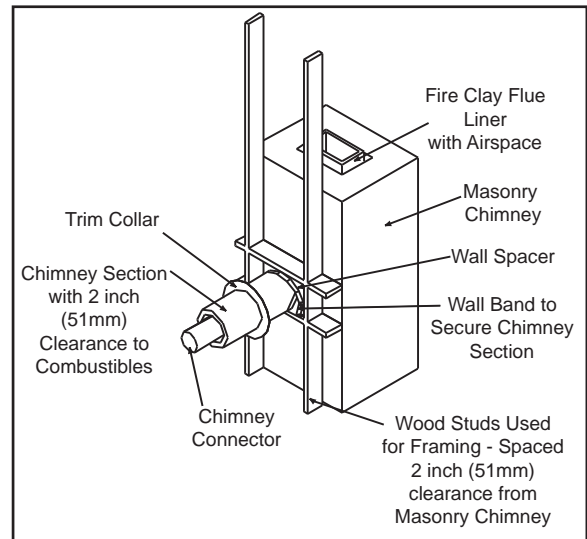
- Masonry chimney clearance must meet NFPA 211 minimum requirement of 2 inches (51mm) to sheet metal supports and combustibles.
- Minimum of 1 inch (25mm) clearance around the chimney connector.
- Top of wall opening is a minimum of 13-1/2 inches (343mm) from ceiling or 4-1/2 inches (114mm) below minimum clearance specified by chimney connector manufacturer. NFPA 211 minimum vertical clearance of 18 inches (457mm) from chimney connector and ceiling or minimum recommended by chimney connector manufacturer. **Figure 19.1.**

**Instructions:**

1. Open inside wall at proper height for the chimney connector to enter the masonry chimney. **Figure 19.1**
2. Entry hole to masonry chimney must be lined with an 8 inch (203mm) minimum diameter clay liner, or equivalent, secured with refractory mortar.
3. Construct a 17 inch x 17 inch (432mm x 432mm) outside dimension frame from 2 x 2 framing lumber to fit into wall opening. Inside opening of frame should be no less than 14 inch x 14 inch (356mm x 356mm). **Figure 19.1.**
4. Attach the wall spacer to the chimney side of the frame.
5. Nail the frame into the wall opening. The spacer should be on the chimney side.
6. Insert the section of the solid insulated chimney into the outer wall of the masonry chimney.
7. Tightly secure the length of the solid insulated chimney with the wall band to the masonry chimney.
8. Insert a section of chimney connector into the chimney. Make sure it does not protrude past the edge of the clay chimney liner inside the chimney.
9. Seal the end of the chimney connector to the clay liner with refractory mortar.
10. Install trim collar around the sold pack chimney section.



**Figure 19.1**



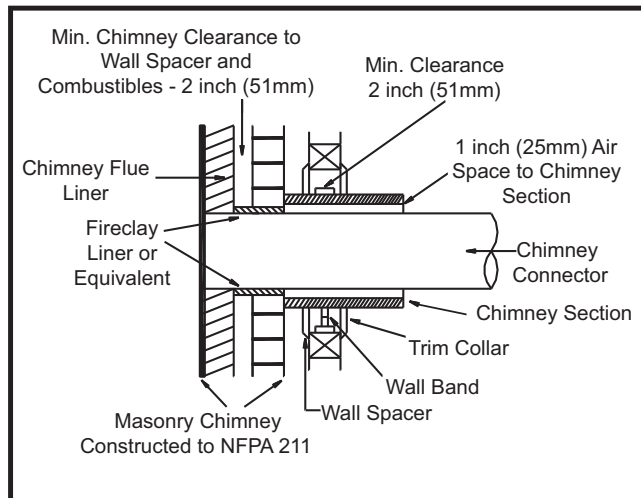
**Figure 19.2 - Solid Pack Chimney with Metal Supports as a Thimble**

**WARNING**

**Fire Risk.**  
Do NOT pack insulation or other combustibles between spacers.

- ALWAYS maintain specified clearances around venting and spacers.
- Install spacers as specified.

Failure to keep insulation or other material away from vent pipe may cause fire.



**Figure 20.1 - Solid Pack Chimney with Metal Supports as a Thimble (Cont'd)**

## Chimney Height / Rise and Run

This product was designed for and tested on a 6 inch (152mm) chimney, 12 to 14 feet (420-480cm) high, (includes stove height) measured from the base of the appliance to the top of the chimney (not including chimney cap). The further your stack height or diameter varies from this configuration, the possibility of performance problems exists.

Chimney height may need to be increased by 2 - 3% per each 1000 feet above sea level. It is not recommended to use offsets or elbows at altitudes above 4000 feet above sea level or when there are other factors that affect flue draft.

## Masonry Chimney Liner

For optimal performance, masonry chimneys used to vent this appliance should be:

1. Lined with a 6 inch (152mm) stainless steel liner.
  - Installations into a clay flue without a stainless steel liner may reduce draw which affects performance, cause the glass to darken and produce excessive creosote.
2. It is recommended that a chimney with a larger diameter than 6 inches (152mm) be relined.
  - The oversized flue can cause poor performance and contribute to the accumulation of creosote.
3. Have the chimney cleaned before the stove is installed and operated.

The following bullets list the more critical requirements for a properly constructed chimney:

- The masonry wall of the chimney, if brick or modular block, must be a minimum of 4 inches (102mm) nominal thickness.
- A chimney of rubble stone must be at least 12 inches (305mm) thick.
- The chimney must have a fire clay flue liner (or equivalent) with a minimum thickness of 5/8 inch (16mm) and must be installed with refractory mortar.
- An equivalent liner must be a listed chimney liner system or other approved material.
- Since an oversized flue contributes to the accumulation of creosote, the size of the flue should be checked to determine that it is not too large for the insert.
- The chimney should also be checked to ensure it meets the minimum standard of the National Fire Protection Association (NFPA) Standard 211.
- A chimney support package must be used when a connection is made through the ceiling to a factory built chimney.
- An approved thimble and chimney support package are **absolutely necessary** to provide safe clearances to combustible wall and ceiling material.

### WARNING

**Fire Risk.**  
Inspection of Chimney:

- Chimney must be in good condition.
- Meets minimum standard of NFPA 211
- Factory-built chimney must be 6 inch (152mm) UL103 HT.

### WARNING

**Asphyxiation Risk.**

- DO NOT CONNECT THIS UNIT TO A CHIMNEY FLUE SERVICING ANOTHER APPLIANCE.
- DO NOT CONNECT TO ANY AIR DISTRIBUTION DUCT OR SYSTEM.

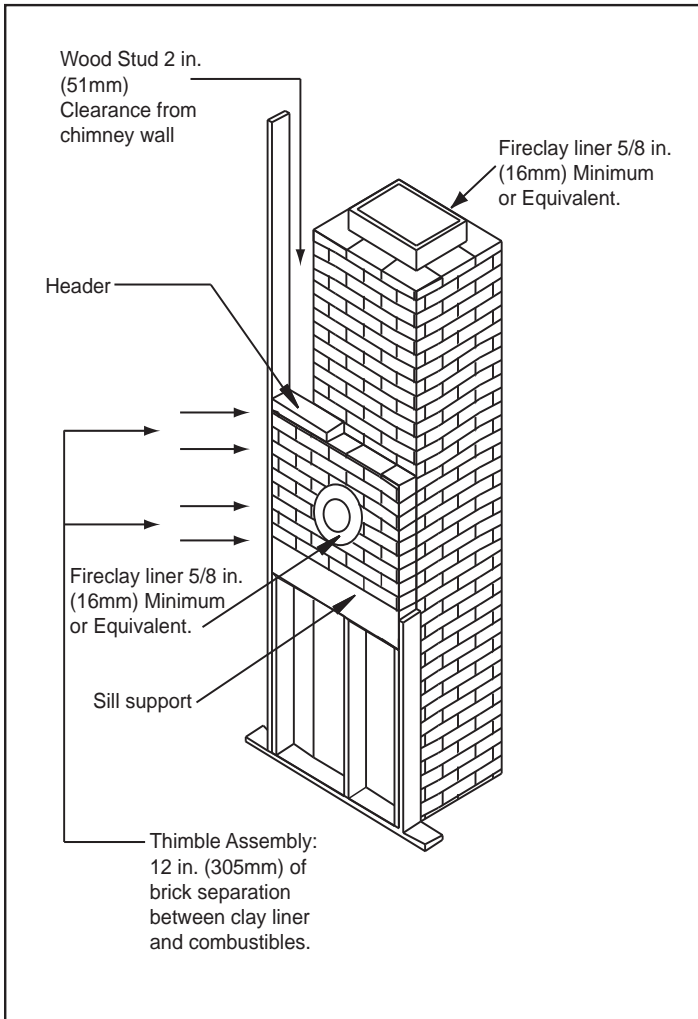
May allow flue gases to enter the house.

**NOTICE:** In Canada, the installation shall conform to CAN/CSA-B365.

**NOTICE:** Check with your local building authorities and/or consult the National Fire Protection Association (NFPA 211).

NOTE: Optional Fire Screen, Part SCR-7006, can only be used in FULL Vertical installations.

**Masonry Chimney Liner (Cont'd)**



**Figure 21.1**

**⚠ WARNING**

Improper installation, adjustment, alteration, service or maintenance can cause injury or property damage. Refer to the owner's information manual provided with this appliance. For assistance or additional information consult a qualified installer, service agency or your dealer.

**ADDITIONAL REQUIRED PARTS FOR REAR INSTALLATION:**

- Baffle Diverter: Shipped with appliance located inside firebox
- Horizontal Flue Heat Shield, Part HTSHLD-7006: Not supplied, must be purchased from your local authorized dealer

**NOTE:** Optional Fire Screen, Part SCR-7006, can only be used in FULL Vertical installations.

**C. Installing Chimney Components**

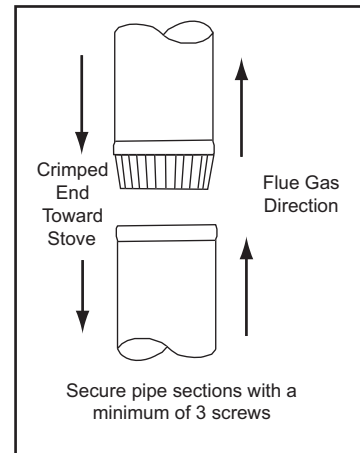
**Chimney Connector**

Single wall connector or stove pipe.

This must be at least 24 gauge mild steel or 26 gauge blue steel. The sections must be attached to the appliance and to each other with the crimped (male) end pointing toward the stove. All joints, including the connection at the flue collar, should be secured with 3 sheet metal screws. Make sure to follow the minimum clearances to combustibles. Where passage through the wall, or partition of combustible construction is desired in Canada, the installation shall conform to CAN/CSA-B365.

Factory-built listed chimney connector (vented).

A listed connector (vented) must be used when installing this unit in a mobile home. The listed connectors must conform to each other to ensure a proper fit and seal.



**Figure 21.2 Chimney Connector (Stove Pipe)**

**⚠ WARNING**

**Fire Risk.**

Follow Chimney Connector Manufacturer's Instructions for Proper Installation.

**ONLY** use connector:

- Within the room, between appliance and ceiling or wall.

Connector shall **NOT** pass through:

- Attic or roof space
- Closet or similar concealed space
- Floor or ceiling

Maintain minimum clearances to combustibles

## D. Chimney Termination Requirements

Follow manufacturer's instructions for clearance, securing flashing and terminating the chimney.

- Must have an approved and Listed cap
- Must not be located where it will become plugged by snow or other material
- Must terminate at least 3 feet (91cm) above the roof **and** at least 2 feet (61cm) above any portion of the roof within 10 feet (305cm).
- Must be located away from trees or other structures

**NOTE:**

- Chimney performance may vary.
- Trees, buildings, roof lines and wind conditions affect performance.
- Chimney height may need adjustment if smoking or overdraft occurs.

## E. 2-10-3 Rule

These are safety requirements and are not meant to assure proper flue draft.

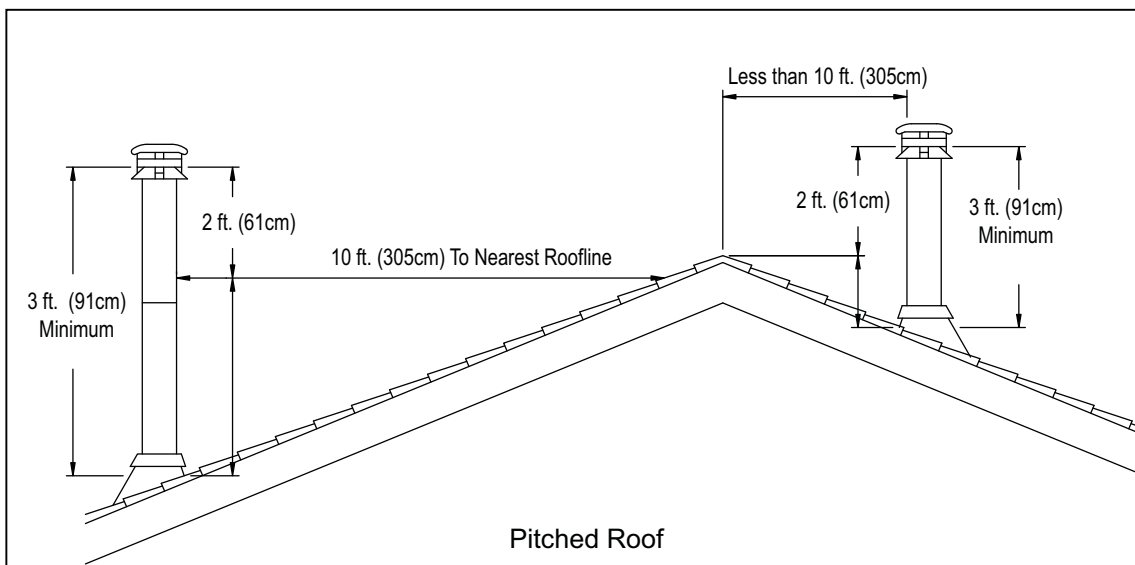


Figure 22.1

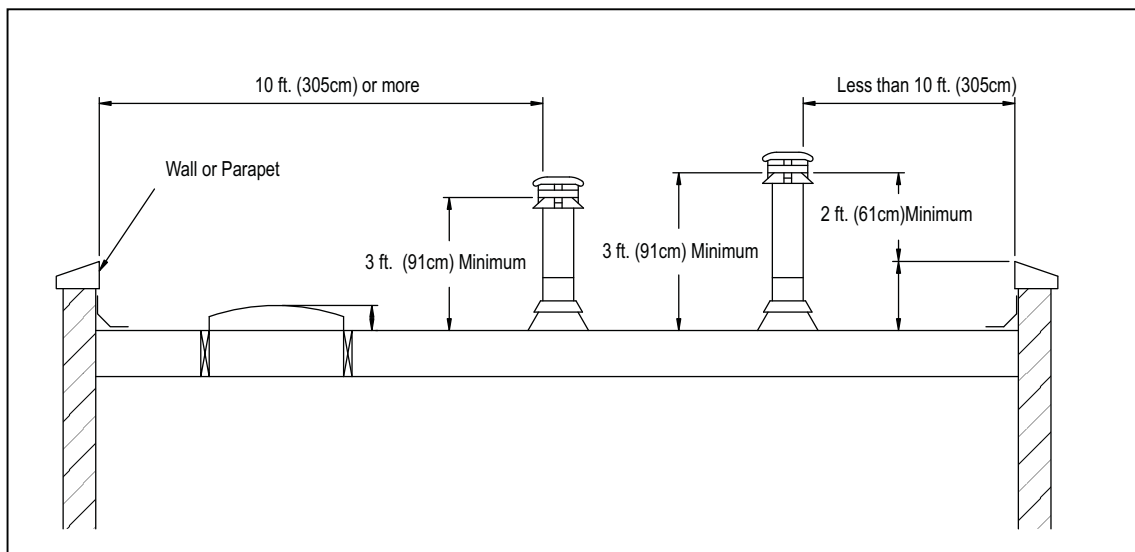


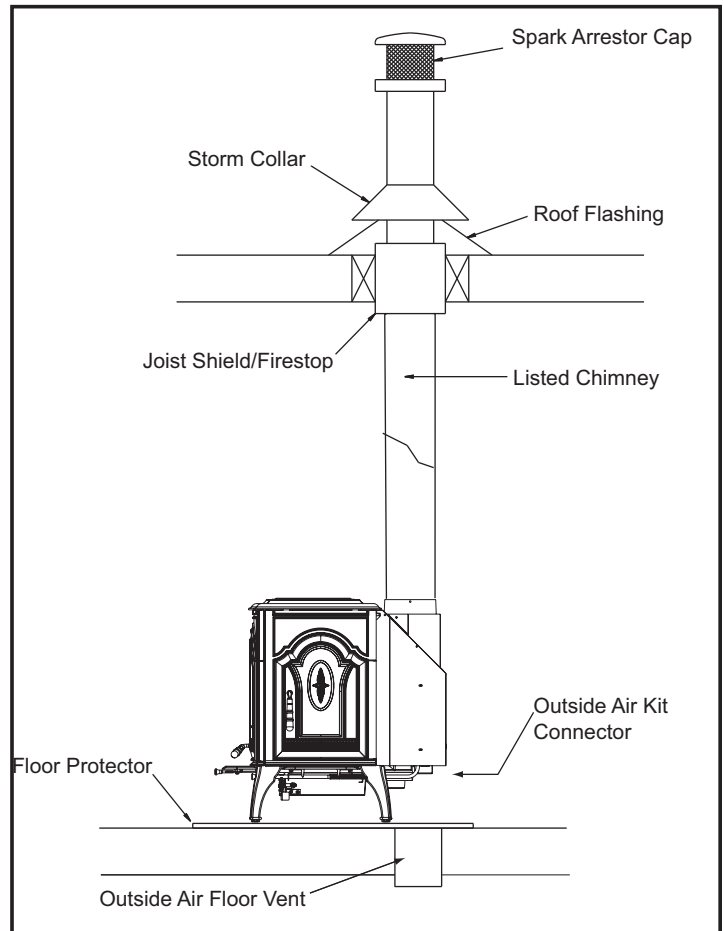
Figure 22.2

# 6

## Mobile Home Installation

**You must use a Quadra-Fire Outside Air Kit Part 831-1780 for installation in a mobile home.**

1. An outside air inlet must be provided for combustion. See **page 17** for installation information.
2. Appliance must be secured to the mobile home structure by bolting the pedestal through hearth pad and into floor.
3. Appliance must be grounded with #8 solid copper grounding wire or equivalent and terminated at each end with N.E.C. approved grounding device.
4. Appliance must be installed with an approved UL103 HT ventilated chimney connector, UL103 HT chimney, and terminal cap with spark arrestor. Never use a single wall connector (stove pipe) in a mobile home installation. Use only double-wall connector pipe, Dura-Vent DVL, Selkirk metalbestos DS or Security DL double-wall connector or any listed double-wall connector pipe.
5. In Canada, this appliance must be connected to a 6 inch (152mm) factory-built chimney conforming to CAN/ULC-629M, STANDARD FOR FACTORY BUILT CHIMNEYS.
6. Follow the chimney and chimney connector manufacturer's instructions when installing the flue system for use in a mobile home.
7. Maintain clearance to combustibles.
8. Floor protection requirements must be followed precisely.
9. Use silicone to create an effective vapor barrier at the location where the chimney or other component penetrates to the exterior of the structure.



**Figure 23.1**

**NOTE:** Offsets from the vertical, not exceeding 45°, are allowed per Section 905(a) of the Uniform Mechanical Code (UMC). Offsets greater than 45° are considered horizontal and are also allowed, providing the horizontal run does not exceed 75% of the vertical height of the vent. Construction, clearance and termination must be in compliance with the UMC Table 9C. This installation must also comply with NFPA 211.

**NOTE:** Top sections of chimney must be removable to allow maximum clearance of 13.5 feet (411 cm) from ground level for transportation purposes.


10. Burn wood only. Other types of fuels may generate poisonous gases (e.g., carbon monoxide).
11. If unit burns poorly while an exhaust blower is on in home, (i.e., range hood), increase combustion air.
12. Installation shall be in accordance with the Manufacturers Home & Safety Standard (HUD) CFR 3280, Part 24.

**CAUTION**

THE STRUCTURAL INTEGRITY OF THE MOBILE HOME FLOOR, WALL AND CEILING/ROOF MUST BE MAINTAINED

Do NOT cut through:

- Floor joist, wall, studs or ceiling trusses.
- Any supporting material that would affect the structural integrity.

 **WARNING**

**Asphyxiation Risk.**

**NEVER INSTALL IN A SLEEPING ROOM.**

Consumes oxygen in the room.

# 7

## Appliance Set-Up

### A. Door Handle Assemblies

All Doors

- Install washer on door handle shaft.
- Slide door handle through door.

Right Front & Side Doors:

- Install additional spacing washer(s) as needed.
- Install bushing, door latch and locknut.

**Caution! Do not overtighten locknut. Door handle needs to move smoothly.**

Left Front Door:

- Install locking pin and locknut. Securely tighten locknut. This handle assembly is stationary.

All Doors

- Insert fiber door handle with threads going into door handle shaft. Turn handle clockwise until tight.

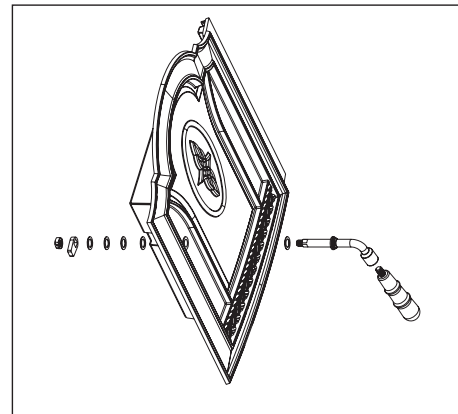


Figure 24.3 - Side Door

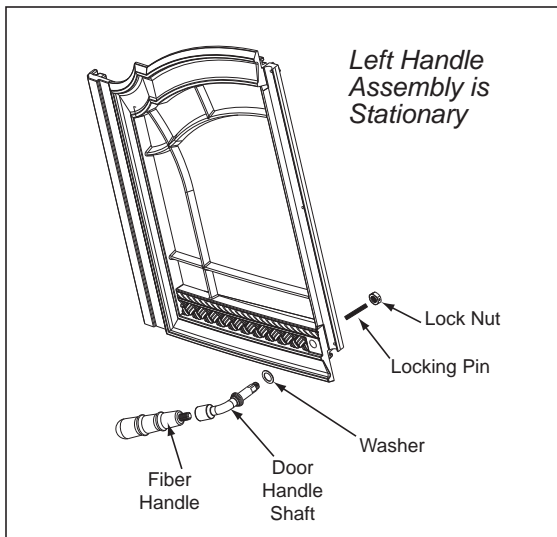


Figure 24.1 - Left Front Door

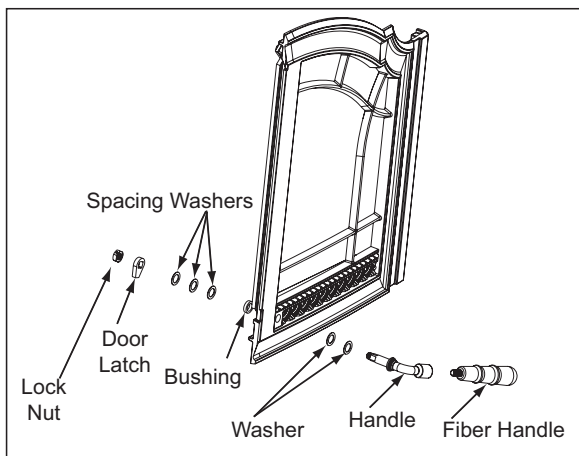


Figure 24.2 - Right Front Door

### B. Adjusting The Blower Speed Control *\*If Necessary*

*\*The blower speed control for this unit is adjusted at the factory, and normally does not require further adjustment.*

**NOTE:** When the speed control is turned clockwise, it will click on to high speed. Turn the speed control clockwise to decrease the speed. At full clockwise, the blower should blow gently, but should not stop.


1. With the stove plugged in, turn the speed control knob to slow (full clockwise).
2. With a small screwdriver, adjust the blower speed by turning the adjustment mechanism through the hole on the side of the speed control.
3. Adjust the speed so the blower runs slowly, but does not stop. Turn clockwise to slow the blower and counterclockwise to increase the speed.




# 8

## Operating Instructions

### A. Over-Firing Your Appliance



### WARNING



**Fire Risk**


Do not over-fire.

Over-firing may ignite creosote or will damage the stove and chimney.


To prevent over-firing your stove, DO NOT:

- Use flammable liquids
- Overload with wood
- Burn trash or large amounts of scrap lumber
- Permit too much air to the fire

### B. Wood Selection and Storage



### WARNING



**FIRE RISK.**

- DO NOT BURN GARBAGE OR FLAMMABLE FLUIDS SUCH AS GASOLINE, NAPHTHA OR ENGINE OIL.
- DO NOT USE CHEMICALS OR FLUIDS TO START A FIRE.
- Do NOT burn treated wood or wood with salt (driftwood).
- May generate carbon monoxide if burn material other than wood.

May result in illness or possible death.

#### 1. Symptoms of Over-Firing

Symptoms of over-firing may include one or more of the following:

- Chimney connector or appliance glowing
- Roaring, rumbling noises
- Loud cracking or banging sounds
- Metal warping
- Chimney fire

#### 2. What To Do if Your Stove is Over-Firing

- Immediately close the door and air controls to reduce air supply to the fire.
- If you suspect a chimney fire, call the fire department and evacuate your house.
- Contact your local chimney professional and have your stove and stove pipe inspected for any damage.
- Do not use your stove until the chimney professional informs you it is safe to do so.

Hearth & Home Technologies WILL NOT warranty stoves that exhibit evidence of over-firing. Evidence of over-firing includes, but is not limited to:

- Warped air tube
- Deteriorated refractory brick retainers
- Deteriorated baffle and other interior components

#### Hardwood vs Softwood

Your appliance performance depends on the quality of the firewood you use.

- Seasoned wood contains about 8,000 BTUs per pound .
- Hard woods are more dense than soft woods.
- Hard woods contain 60% more BTUs than soft woods.
- Hard woods require more time to season, burn slower and are harder to ignite.
- Soft woods require less time to dry, burn faster and are easier to ignite.
- Start the fire with softwood to bring the appliance up to operating temperature and to establish draft.
- Add hardwood for slow, even heat and longer burn time.

Soft woods	Hard woods
<ul style="list-style-type: none"> <li>• Douglas Fir</li> <li>• Pine</li> <li>• Spruce</li> <li>• Cedar</li> </ul>	<ul style="list-style-type: none"> <li>• Oak</li> <li>• Maple</li> <li>• Apple</li> <li>• Birch</li> <li>• Poplar</li> <li>• Aspen</li> <li>• Alder</li> </ul>



#### Processed Solid Fuel Fire Logs

- NOT permitted for use in this appliance

## Moisture

The majority of the problems appliance owners experience are caused by trying to burn wet, unseasoned wood.

- Wet, unseasoned wood requires energy to evaporate the water instead of heating your home, and
- Causes evaporating moisture which cools your chimney, accelerating formation of creosote.

 <b>WARNING</b>	
	<b>Fire Risk.</b>
	<ul style="list-style-type: none"><li>• Do NOT burn wet or green wood.</li><li>• Store wood in dry location.</li><li>• Stack wood so both ends are exposed to air.</li></ul> Wet, unseasoned wood can cause accumulation of creosote.

## Seasoned Wood



- Cut logs to size
- Split to 6 inches (152 mm) or less in diameter
- Air dry to a moisture content of not more than 20%
  - Soft wood - about nine months to dry
  - Hard wood - about eighteen months to dry

**NOTICE:** Seasoning time may vary depending on drying conditions.

## Storing Wood

Steps to ensure properly seasoned wood:

- Stack wood to allow air to circulate freely around and through woodpile.
- Elevate wood pile off ground to allow air circulation underneath.
- Smaller pieces of wood dry faster. Any piece over 6 in. (152 mm) in diameter should be split.
- Wood (whole or split) should be stacked so both ends of each piece are exposed to air. More drying occurs through the cut ends than the sides.
- Store wood under cover to prevent water absorption from rain or snow. Avoid covering the sides and ends completely.

 <b>WARNING</b>	
	<b>Fire Risk</b>
	Do NOT store wood: <ul style="list-style-type: none"><li>• In front of the appliance.</li><li>• In space required for loading or ash removal.</li></ul>

## C. Burning Process

In recent years there has been an increasing concern about air quality. Much of the blame for poor air quality has been placed on the burning of wood for home heating.

In order to improve the situation, we at Quadra-Fire have developed cleaner-burning wood appliances that surpass the requirements for emissions established by our governing agencies.

These wood appliances must be properly operated in order to ensure that they perform the way they are designed to perform.

**NOTICE:** Improper operation can turn any wood appliance into a smoldering environmental hazard.

### 1. Kindling or First Stage

It helps to know a little about the actual process of burning in order to understand what goes on inside the appliance. The first stage of burning is called the kindling stage.

In this stage:

- Wood is heated to a temperature high enough to evaporate the moisture present in all wood.
- Wood will reach the boiling point of water (212°F) and will not get any hotter until the water is evaporated.

This process takes heat from the coals and tends to cool the appliance.

Fire requires three things to burn:

- Fuel
- Air
- Heat

If heat is robbed from the appliance during the drying stage, the new load of wood has reduced the chances for a good clean burn.

It is always best to burn dry, seasoned firewood. When the wood isn't dry, you must open the air controls and burn at a high burn setting for a longer time to start it burning.

The heat generated from the fire should be warming your home and establishing the flue draft, not evaporating the moisture out of wet, unseasoned wood, resulting in wasted heat.

### 2. Second Stage

In the secondary stage wood gives off flammable gases which burn above the fuel with bright flames.

During this stage of burning:

- The flames must be maintained and not allowed to go out to ensure the cleanest possible fire.
- If the flames tend to go out, it is set too low for your burning conditions.

The Primary Air Slide Control located under the ashlip adjusts the burn rates. **Figure 27.1.**

**3. Final Stage**

The final stage of burning is the charcoal stage. This occurs when the flammable gases have been mostly burned and only charcoal remains. This is a naturally clean portion of the burn. The coals burn with hot blue flames.

- It is very important to reload your appliance while enough lively hot coals remain in order to provide the amount of heat needed to dry and rekindle the next load of wood.
- It is best to open the Primary Air Control and the Start-Up Air Controls **before reloading**. This livens up the coalbed and reduces excessive emissions (opacity/smoke).
- Open door slowly so that ash or smoke does not exit appliance through opening.
- Break up any large chunks and distribute the coals so that the new wood is laid on hot coals.

Air quality is important to all of us, and if we choose to use wood to heat our homes we should do so responsibly.

We need to learn to burn in the cleanest way possible allowing us to continue using our wood appliances for many years to come.

**D. Combustible/Non-Combustible Materials**

**• Combustible Material**

Material made of or surfaced with wood, compressed paper, plant fibers, plastics, or any material capable of igniting and burning, whether flame-proofed or not, plastered or unplastered.

**• Non-Combustible Material**

Material which will not ignite and burn. Such materials are those consisting entirely of steel, iron, brick, tile, slate, glass or plasters, or any combination thereof.

Materials that are reported as passing ASTM E 136, Standard Test Method for Behavior of Materials in a Vertical Tube Furnance at 750 °C and UL763 shall be considered non-combustible materials.

**• Non-Combustible Sealant Material**

Sealants which will not ignite and burn: Rutland, Inc. Fireplace Mortar #63, Rutland 76R, Nuflex 304, GE RTV106 or GE RTB116 (or equivalent).

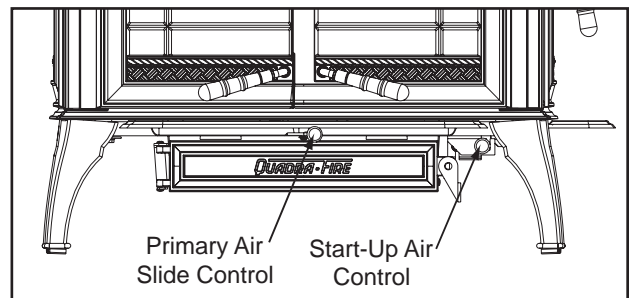
**E. Air Controls**

**Start-Up Air System**

The combustion air enters at the rear of the firebox through the rear air tubes. This air supply is controlled by the Start-up Air Control. For more air push control **IN**, for less air pull control **OUT**.

**Primary Air System**

The primary air enters below the ash catcher and is directed to the upper front of the firebox, near the top of the glass door and to the lower front of firebox. This preheated air supplies the necessary fresh oxygen to mix with the unburned gases, helping to create secondary, tertiary and quaternary combustions. This air is regulated by the Primary Air Slide Control. For more primary air slide control **LEFT**, for less air slide control **RIGHT**.



**Figure 27.1**

Primary Slide Control


**OPEN - SLIDE LEFT**


**CLOSE SLIDE RIGHT**

Start-Up Air Control

**OPEN - PUSH IN**

**CLOSE - PULL OUT**

 **WARNING**

 **Fire Risk.**

- ALWAYS OPERATE THIS APPLIANCE WITH THE DOOR CLOSED AND LATCHED EXCEPT DURING START-UP AND RE-FUELING OR WHEN USING THE FIRESCREEN.
- OPERATING WITH THE DOOR PARTLY OPEN CAN CAUSE:
  - HOT EMBERS OR SPARKS TO FALL OUT
  - FLAMES AND SMOKE MAY BE DRAWN OUT FROM FIREBOX OPENING

## F. Heat Output Settings

For maximum operating efficiency with the lowest emissions, follow these operating procedures:

1. Regardless of desired heat output, when loading stove, burn it with both air controls wide open for 5 to 15 minutes.
2. Regulate burn rate (heat output) by using the Primary Air Slide Control (center under ashcatcher). The Start-Up Air Control (on the right) is used for initial start-up and reloading.
3. Heat output settings are listed below, following 5 to 15 minutes of burning with controls wide open (see #1 above):
4. Burn dry, well-seasoned wood.

## G. Burn Rates

### 1. High Burn Rate - Maximum Heat\* - 30,000+ BTU/hr

- Close Start-Up Air Control after 5 to 15 minutes, fully open (slide all the way to the left) the Primary Air Slide Control.

### 2. Medium-High Burn Rate\* - 15,000 to 30,000 BTU/hr

- Close Start-Up Air Control after 5 to 15 minutes, open the Primary Air Control 1/4 inch to 1 inch.

### 3. Medium-Low Burn Rate\* - 10,000 to 15,000 BTU/hr

- Close Start-Up Air Control after 5 to 15 minutes, open the Primary Air Control 1/8 inch to 1/4 inch.

### 4. Low Burn Rate\* - Below 10,000 BTU/hr

- Close Start-Up Air Control after 5 to 15 minutes. Gradually close down (sliding to the right) the Primary Air Slide Control making sure to maintain flames in the stove. You must maintain flames during the first few hours of a low burn to avoid excessive air pollution.

**\*NOTE:** These are approximate settings, and will vary with type of wood or chimney draft. Due to altitude and other environmental circumstances, this operational information is a guideline only.



## WARNING

### Risk of extreme temperatures!

- Do not operate with Start-Up Air Control in the open position in excess of 15 minutes!
- Prolonged operation with the Start-Up Air Control in the open position may cause the combustible materials around the stove to exceed safe temperature limits.

## H. Building A Fire



*Before lighting your first fire make certain that the baffle and blanket are correctly positioned. They should be resting against the rear support.*



There are many ways to build a fire. The basic principle is to light easily-ignitable tinder or paper, which ignites the fast burning kindling, which in turn ignites the slow-burning firewood. Here is one method that works well:

1. Place several wads of crushed paper on the firebox floor. **Heating the flue with slightly crumpled newspaper before adding kindling keeps smoke to a minimum.**
2. Lay small dry sticks of kindling on top of the paper.
3. Open Start-Up Air Control and Primary Air Slide Control fully. After 5 to 15 minutes, when the fire is well established, gently pull Start-Up Air Control forward until resistance is felt. Do not allow control to "spring back" into the open position.
4. Make sure that no matches or other combustibles are in the immediate area of the stove. Be sure the room is adequately ventilated and the flue unobstructed.
5. Light the paper in the stove. NEVER light or rekindle stove with kerosene, gasoline, or charcoal lighter fluid; the results can be fatal.
6. Once the kindling is burning quickly, add several full-length logs 3 inches (76mm) or 4 inches (102mm) in diameter. Be careful not to smother the fire. Stack the pieces of wood carefully: near enough to keep each other hot, but far enough away from each other to allow adequate air flow between them.
7. When ready to reload the stove, add more logs. Large logs burn slowly, holding a fire longer. Small logs burn fast and hot, giving quick heat.
8. Adjust the Start-Up Air Control and Primary Air Slide Control; the more you close down (slide right) the Primary Air Slide Control, the lower and slower the fire will burn. The more you open (slide left) the Primary Air Slide Control, the more heat will be produced. The Start-Up Air Control is only used for the first 5 to 15 minutes.
9. As long as there are hot coals, repeating steps 7 and 8 will maintain a continuous fire throughout the season.

**NOTE:** The special high temperature paint that your stove is finished with will cure as your stove heats. You will notice an odor and perhaps see some vapor rise from the stove surface; this is normal. We recommend that you open a window until the odor dissipates and paint is cured.

**NOTE:** Stove should be run full open for 15 minutes a day to keep air passages clean.

	<b>WARNING</b>
	<p><b>Fire Risk.</b></p> <ul style="list-style-type: none"> <li>• DO NOT BURN GARBAGE OR FLAMMABLE FLUIDS SUCH AS GASOLINE, NAPTHA OR ENGINE OIL.</li> <li>• Do NOT burn treated wood or wood with salt (driftwood).</li> <li>• May generate carbon monoxide if burn material other than wood.</li> </ul> <p>May result in illness or possible death.</p>

	<b>WARNING</b>
	<p><b>Fire Risk.</b></p> <p>Keep combustible materials, gasoline and other flammable vapors and liquids clear of appliance.</p> <ul style="list-style-type: none"> <li>• Do NOT store flammable materials in the appliance's vicinity.</li> <li>• DO NOT USE GASOLINE, LANTERN FUEL, KEROSENE, CHARCOAL LIGHTER FLUID OR SIMILAR LIQUIDS TO START OR "FRESHEN UP" A FIRE IN THIS HEATER.</li> <li>• Keep all such liquids well away from the heater while it is in use.</li> <li>• Combustible materials may ignite.</li> </ul>

<b>CAUTION</b>
<p>Odors and vapors released during initial operation.</p> <ul style="list-style-type: none"> <li>• Curing of high temperature paint.</li> <li>• Open windows for air circulation.</li> </ul> <p>Odors may be irritating to sensitive individuals.</p>

<p><b>NOTE:</b></p> <ul style="list-style-type: none"> <li>• Build fire on brick firebox floor.</li> <li>• Do NOT use grates, andirons or other methods to support fuel.</li> </ul> <p>It will averserly affect emissions.</p>
--

**I. Optional Blower Operating Instructions**

1. **Initial (cold) start-up:** Leave blower off until your stove is hot and a good coalbed is established. The blower may be turned on approximately 30 minutes after a good coalbed is established.
2. **High burn setting:** The blower may be left on throughout the burn at your desired setting.
3. **Medium burn settings:** The blower should be left off until a good burn is established, then turned on at your desired setting.
4. **Low burn setting:** The blower tends to cool off the stove. Leave blower off until burn is well established. Then turn on at your desired rate.
5. The highest blower speed is obtained by turning the speed control on and then adjusting counterclockwise towards "OFF" as far as possible without turning the blower off. For a low blower speed, turn the control knob clockwise as far as possible.

**J. Opacity (Smoke)**

Opacity is the measure of how cleanly your appliance is burning.

Opacity is measured in percent:



- 100% opacity is when an object is totally obscured by the smoke column from a chimney, and
- 0% opacity means that no smoke column can be seen.

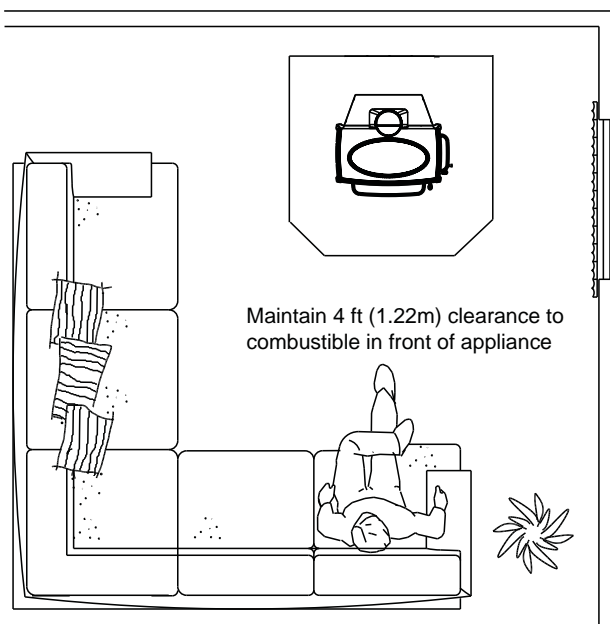
As you become familiar with your appliance, you should periodically check the opacity. This will allow you to know how to burn as nearly smoke-free as possible (goal of 0% opacity).

<b>WARNING !</b>
<ul style="list-style-type: none"> <li>• The outside surfaces of this unit will become extremely hot during use.</li> <li>• If this appliance is in a high traffic area or children may be near it is recommended that you purchase a decorative barrier to go in front of the appliance.</li> <li>• Always keep children away while it is operating</li> <li>• Do not let anyone operate this appliance unless they are familiar with these operation instructions.</li> </ul>

**K. Clear Space**

- Do NOT place combustible objects within 4 ft (1.2 m) of the front of fireplace. **Figure 30.1.**

	<p><b>WARNING</b></p>
	<p><b>Fire Risk.</b></p> <ul style="list-style-type: none"> <li>• Do not place combustible objects within 48 inches in front of the appliance.</li> <li>• High temperatures may ignite clothing, furniture or draperies.</li> </ul>




**Figure 30.1 - Clear Space**

**L. Frequently Asked Questions**

ISSUES	SOLUTIONS
Odor from appliance	When first operated, this appliance may release an odor for the first several hours. This is caused by the curing of the paint and the burning off of any oils remaining from manufacturing.
Metallic noise	Noise is caused by metal expanding and contracting as it heats up and cools down, similar to the sound produced by a furnace or heating duct. This noise does not affect the operation or longevity of the appliance.
Whirring sound	The blower may produce a whirring sound which increases in volume as the speed is increased.

**M. Correct Baffle & Blanket Placement**



## WARNING

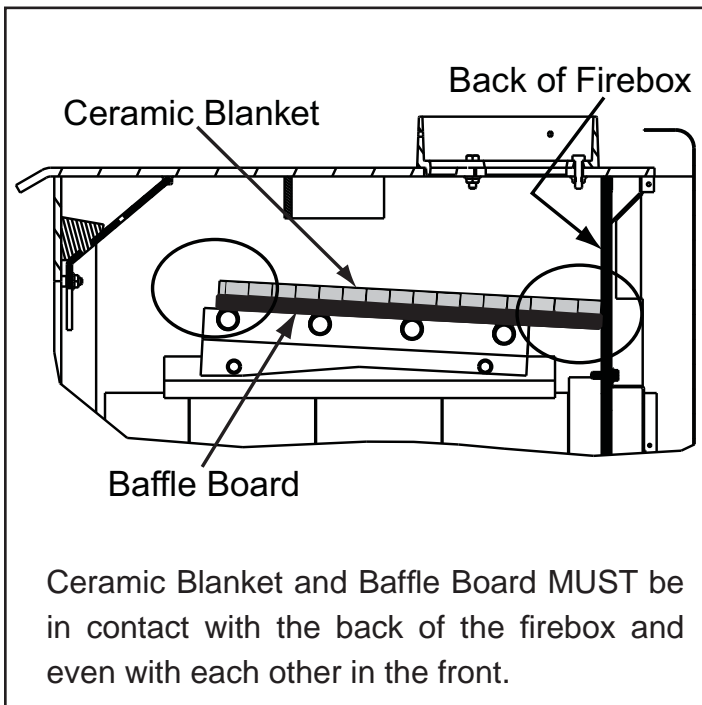
**Fire Risk**  
Firebox damage due to improper baffle placement is not covered by warranty. Operate the wood burning appliance with the baffle in the correct position only. Not doing so could result in:

- Reduced efficiency
- Overheating the chimney
- Overheating the rear of the firebox
- Poor performance

Ensure correct baffle placement and replace baffle components if damaged or missing.

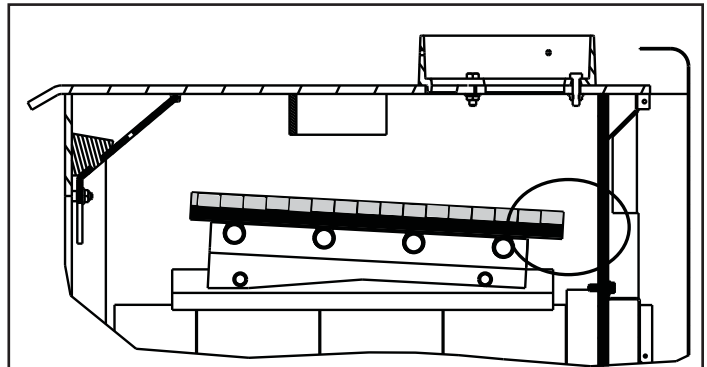
*These are generic drawings and may not represent your specific model.*

**CORRECT POSITION**

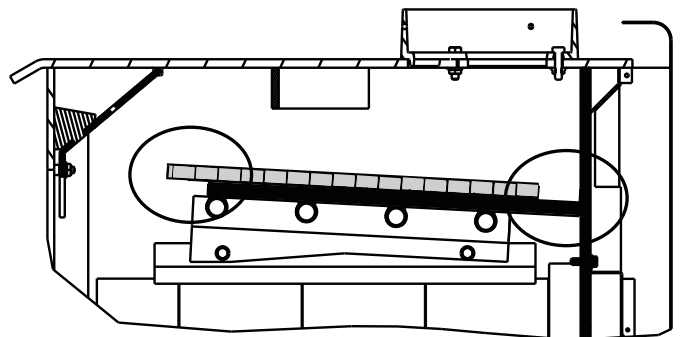


**Figure 31.1**

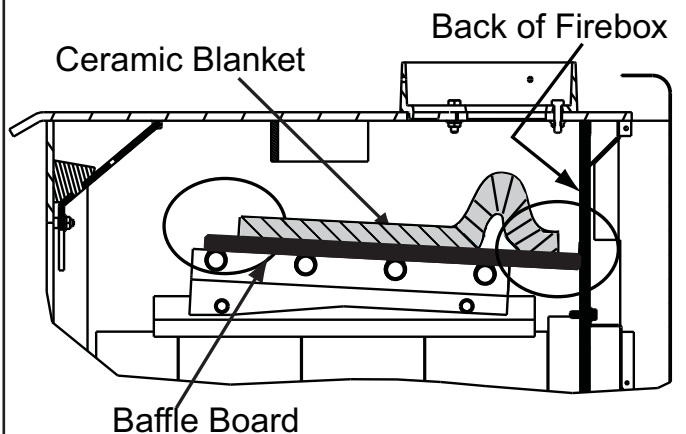
**INCORRECT POSITIONS**



Ceramic Blanket and Baffle Board are **NOT** in contact with the back of the firebox.



Ceramic Blanket is **NOT** in contact with the back of the firebox and **NOT** even with the Baffle Board in the front.



Ceramic Blanket is bunched up at the back of the firebox and **NOT** even with the Baffle Board in the front.

**Figure 31.2**

# 9

## Maintaining & Servicing Your Appliance

### A. General Maintenance

#### 1. Creosote (Chimney) Cleaning

- **Frequency:** Every 2 months during heating season or as recommended by a certified chimney sweep; more frequently if chimney exceeds or is under 12-14 ft. (measured from base of appliance).
  - **By:** Certified Chimney Sweep
1. Remove all ash from the firebox and extinguish all hot embers before disposal. Allow the appliance to cool completely. It is also recommended that before each heating season the entire system be professionally inspected, cleaned and repaired if necessary.
  2. Close the door tightly and proceed with sweeping the chimney.
  3. Sweep the collected ashes into the ash removal box, and empty. Clean out the remaining ashes from firebox.
  4. Open top-loading door and vacuum out.

**Inspection:** Inspect the system at the appliance connection and at the chimney top. Cooler surfaces tend to build creosote deposits quicker, so it is important to check the chimney from the top as well as from the bottom.



**Formation and Need For Removal:** When wood is burned slowly, it produces tar and other organic vapors which combine with expelled moisture to form creosote.

The creosote vapors condense in the relatively cool chimney flue of a newly-started or a slow-burning fire. As a result, creosote residue accumulates on the flue lining. When ignited, this creosote creates an extremely hot fire which may damage the chimney or even destroy the house.

The chimney connector and chimney should be inspected once every 2 months during the heating season to determine if a creosote or soot buildup has occurred. If creosote or soot has accumulated, it should be removed to reduce the risk of a chimney fire.

#### 2. Ash Removal System (ARS) Operating and Cleaning

- **Frequency:** Weekly when in constant operation or as needed.
- **By:** Homeowner

	 <b>CAUTION</b>
<b>Injury Risk.</b>	
<ul style="list-style-type: none"> <li>• Gloves recommended</li> <li>• Ash coals can remain extremely hot for several days.</li> </ul>	

1. The stove and ashes must be completely cooled down before using the Ash Removal System. The hinged door will open from the right hand side. Pull ash pan out carefully.
2. Clean ash down through the ash removal system grate into the drawer below. If there are large pieces in the ashes, you can remove the grate before brushing the ash into the drawer.
3. Be sure to replace the grate before operating the stove. Remember to leave 1/4 to 1/2 inch (6-13mm) of ash on the firebox floor to act as a natural grate, allowing air to flow freely underneath wood
4. Replace ash pan and close ash door handle. Dispose of the ashes following the directions on **page 33**.

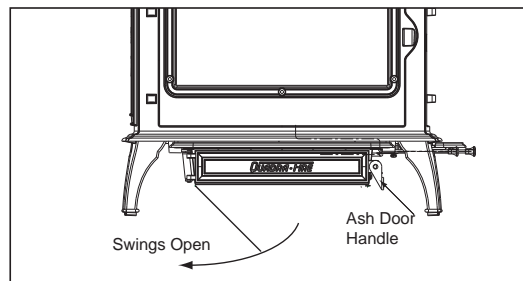








Figure 32.1

**Do not allow ashes to build up in the ashpan until they reach the grate. This will lead to premature deterioration of the grate and make it difficult to empty the ash pan.**

	<b>WARNING</b>
	<p><b>Fire Risk.</b> Prevent creosote buildup.</p> <ul style="list-style-type: none"> <li>• Inspect chimney connector and chimney once every two months during heating season.</li> <li>• Remove creosote to reduce risk of chimney fire.</li> <li>• Ignited creosote is extremely HOT.</li> </ul>

	<b>WARNING</b>
	<p><b>Fire Risk.</b></p> <ul style="list-style-type: none"> <li>• Do not use chimney cleaners or flame colorants in your appliance.</li> </ul> <p>Will corrode pipe.</p>

	<b>WARNING</b>
	<p><b>Fire risk</b> <b>Injury risk</b></p> <p>Make sure ash removal system door Air leakage may cause:</p> <ul style="list-style-type: none"> <li>• Over-fire condition.</li> <li>• Flame and/or smoke spillage.</li> <li>• Wood to burn too fast.</li> </ul> <p><b>Do not operate with ash pan door open or with ash pan removed</b></p>




**3. Disposal of Ashes**

- **Frequency:** When ash is within 1-3/4 in. (44mm) of firebox lip
- **By:** Homeowner

Ashes should be placed in a metal container with a tight fitting lid. The closed container of ashes should be placed on a non-combustible floor or on the ground, well away from all combustible materials, pending final disposal.

If the ashes are disposed of by burial in soil or otherwise locally dispersed, they should be retained in the closed container until all cinders have thoroughly cooled.

	<p><b>WARNING</b></p>
<p><b>Fire Risk.</b> <b>Disposal of Ashes</b></p> <ul style="list-style-type: none"> <li>• Ashes should be placed in metal container with tight fitting lid.</li> <li>• Do not place metal container on combustible surface.</li> <li>• Ashes should be retained in closed container until all cinders have thoroughly cooled.</li> </ul>	

**4. Cleaning Plated Surfaces**

- **Frequency:** Prior to first burn and then as desired
- **By:** Homeowner

Clean all the fingerprints and oils from plated surfaces **BEFORE** firing the appliance for the first time. If not cleaned properly before lighting your first fire, the oils can cause permanent markings on the plating.

After the plating is cured, the oils will not affect the finish and little maintenance is required. Wipe clean as needed.

<p><b>CAUTION</b></p>
<ul style="list-style-type: none"> <li>• Do not use polishes with abrasives.</li> </ul> <p>It will scratch plated surfaces.</p>

**5. Glass Cleaning**

- **Frequency:** As desired
- **By:** Homeowner

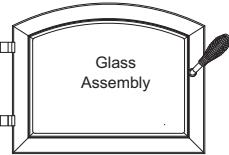
Clean glass with a non-abrasive glass cleaner. Abrasive cleaners may scratch and cause glass to crack. If the deposits on the glass are not very heavy, normal glass cleaners work well. Heavier deposits may be removed by using a damp cloth dipped in wood ashes or by using a commercially available oven cleaner.

After using an oven cleaner, it is advisable to remove any residue with a glass cleaner or soap and water. Oven cleaner left on during the next firing can permanently stain the glass and damage the finish on plated metal surfaces.

A portion of the combustion air entering the firebox is deflected down over the inside of the door glass. This air flow “washes” the glass, helping to keep smoke from adhering to its surface.

When operated at a low burn rate, less air will be flowing over the glass and the smokey, relatively cool condition of a low fire will cause the glass to become coated.

Operating the appliance with the Primary Air Control all the way open for 15-20 minutes should remove the built up coating.

<p><b>CAUTION</b></p>	
	<p>Handle glass assembly with care.</p> <p><b>When cleaning glass:</b></p> <ul style="list-style-type: none"> <li>• Avoid striking, scratching or slamming glass.</li> <li>• Do NOT clean glass when hot.</li> </ul>
<ul style="list-style-type: none"> <li>• Do NOT use abrasive cleaners.</li> <li>• Use a hard water deposit glass cleaner on white film.</li> <li>• Use commercial oven cleaner on heavier deposits.</li> <li>• Remove all residue of oven cleaner or will permanently stain glass on next firing.</li> </ul>	
<ul style="list-style-type: none"> <li>• Refer to maintenance instructions.</li> </ul>	

## B. Appliance Inspection - Routine

- **Frequency:** Every 2 months at the same time the chimney and chimney connector are inspected.
- **By:** Homeowner

Check for:

- Cracks in glass
- Door handle - smooth cam operation
- Baffles are in correct placement
- Baffle for warpage
- Firebrick for cracks, broken or crumbly
- Door gasket. (Dollar bill test). Place a dollar bill between the stove and the door and then shut the door. If you can pull the dollar bill out, replace the door gasket.
- Glass frame for loose screws

## C. Inspect Firebrick & Replacement Instructions

- **Frequency:** After each ash removal
- **By:** Homeowner

Replace the firebrick if they become crumbly and/or if there is a 1/4 inch (6.35mm) gap between the bricks.

The firebox is lined with firebrick, which has exceptional insulating properties. Do not use a grate; simply build a fire on the firebox floor. Do not operate appliance without firebrick.

Ensure that the firebricks are correctly positioned and that the firebox does not contain any broken brick prior to operating the unit.

1. After the coals have completely cooled, remove all old brick and ash from unit and vacuum out firebox.
2. Remove new brick set from box and lay out to the diagram shown in the instructions that come with the replacement brick set
3. Lay bottom bricks in unit.
4. Install rear bricks on the top of the bottom bricks. Slide top of bricks under clip on back of firebox wall and push bottom of bricks back.
5. Install side bricks. Slide top of brick under clips on side of firebox and push the bottom of the brick until it is flush with the side of the unit.

**Use Part #832-0550 when ordering individual brick. Provide brick dimension or copy the page in the Service Parts List showing the brick diagram, mark the desired brick and take it to your authorized dealer.**

## D. Glass Replacement

1. Ensure that the fire is out and the appliance is cool to the touch.
2. Protect a table or counter top with padding or towels. Protect your hands and wear gloves to prevent injury.
3. Remove the door with the broken glass by lifting the door up and off of the hinges.
4. Lay door face down on a table or counter making sure the door handle and fiber handle hangs over the edge so the door lays flat on a soft surface.
5. Remove the screws from each glass retainer and remove the glass. (If screws are difficult to remove, soak with penetrating oil first).
6. Center the glass with edges evenly overlapping the opening in the door, (i.e. same space top and bottom, left and right sides).
7. Replace the glass retainers. Be careful not to cross thread the screws.
8. Tighten each retainer just a few turns until each is secured. Check again for centering of glass in door frame. Continue to tighten each retainer alternately, a few turns at a time, until the glass is snug. **DO NOT OVERTIGHTEN.**
9. Replace the door on the appliance.

Quadra-Fire stoves are equipped with ceramic super heat-resistant glass, which can only be broken by impact or misuse.

Do not slam stove door or impact the glass. When closing door, make sure that logs do not protrude against the glass. Inspect glass regularly.

If you find a crack or break, immediately put the fire out and return the door to your dealer for replacement of glass before further use.

**WARNING**

**Handle glass with care.**

- Inspect the gasket to ensure it is undamaged.
- Do NOT strike, slam or scratch glass.
- Do NOT operate appliance with glass & door assembly removed.

- Do NOT operate with glass cracked, broken or scratched.

**WARNING**

**Fire Risk.**

**Injury Risk.**

- Use only glass specified in manual.
- DO NOT REPLACE with any other material.

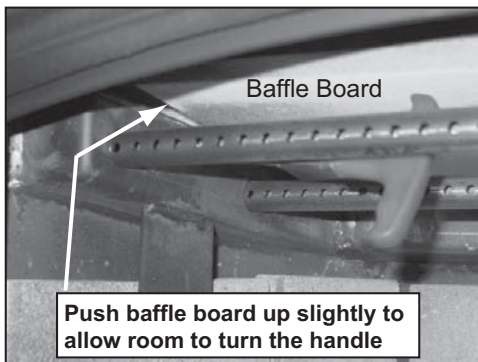
Glass breakage will occur.

## E. Baffle Removal & Installation

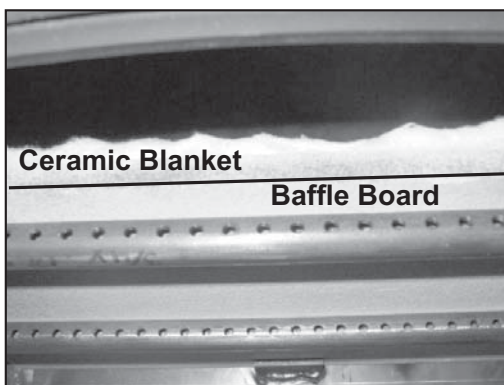
1. Remove all ash from firebox, and extinguish all hot embers before disposal into a metal container.
2. Remove ceramic blanket & baffle together
3. With a 3/16" Allen wrench, remove the front manifold tube retainer bolts on the air channel under the end of the front tube. **Figure 35.1.**

**NOTE:** Soak the bolts with penetrating oil for at least 15 minutes before trying to remove them.

4. To remove manifold tube, slide the tube to one side until one end is out of its hole. Then, while lifting that end of the fiber board baffle, pull tube up over the air channel and out of hole at the other end.
5. Slide fiber board baffle forward to front of stove and straight out through door. **Figure 35.2.**
6. To install the fiber board baffle, repeat steps 2 through 4 in reverse.
7. The front manifold tube is shorter than the back two. It is **IMPORTANT** that they are replaced in the correct position or your stove will not operate properly.
8. Be sure the fiber board baffle and ceramic blanket are fully pushed back into position and the blanket is down flat. The front of the blanket should be flush with the front of the baffle.



**Figure 35.1**

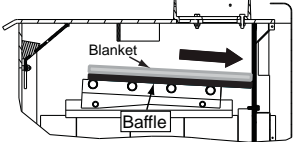
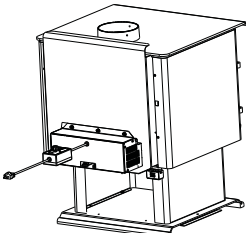
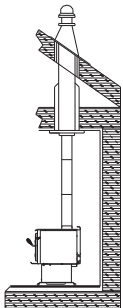
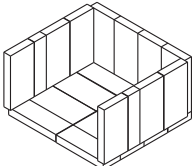
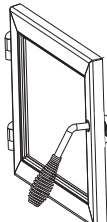
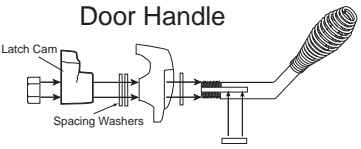


**Figure 35.2**

## F. Quick Reference Maintenance Guide

**CAUTION!** Allow the appliance to completely cool down before performing any cleaning or maintenance.

Start the first inspection after the first 2 months of use, or if performance changes, and adjust your schedule accordingly. Maintenance is required for safe operation and must be performed to maintain your warranty.

	Frequency	Task
<p><b>Baffle &amp; Blanket</b></p> 	<p>MONTHLY or After Every Cord of Wood</p>	<p>Baffle and blanket placement is critical to heat output, efficiency and overall life of the unit. Make sure the baffle is pushed all of the way to the back of the firebox and the blanket is laying flat. Inspect baffle for cracks.</p>
<p><b>Optional Blower</b></p> 	<p>YEARLY or After Every 4 Cords of Wood</p>	<p>Vacuum the blower impellers.</p>
<p><b>Chimney System</b></p> 	<p>EVERY 2 MONTHS or After Every 4 Cords of Wood</p>	<p>The chimney and chimney cap must be inspected for soot and creosote every two months during the burn season or more frequency if chimney exceeds or is under 14-16 ft (4.3m-4.8m) measured from bottom of appliance.</p> <p>This will prevent pipe blockage, poor draft, and chimney fires.</p> <p>Always burn dry wood to help prevent cap blockage and creosote build-up.</p>
<p><b>Firebrick &amp; Ash Removal</b></p> 	<p>WEEKLY or After Every 25 Loads of Wood</p>	<p>Ashes must be cool before you can dispose of the ashes in a non-combustible container.</p> <p>Firebrick is designed to protect your firebox. After ashes are removed, inspect the firebrick and replace firebricks that are crumbling, cracked or broken.</p>
<p><b>Door &amp; Glass Assemblies</b></p> 	<p>WEEKLY or After Every 25 Loads of Wood</p>	<p>Keep door and glass gasket in good shape to maintain good burn times on a low burn setting. To test: place a dollar bill between the stove and door and then shut the door. If you can pull the dollar out, remove one washer from door handle behind latch cam and try again. If you can still pull it out, replace the door gasket.</p> <p>Check the glass frame for loose screws to prevent air leakage. Check glass for cracks.</p>
<p><b>Door Handle</b></p> 	<p>WEEKLY or After Every 25 Loads of Wood</p>	<p>Check the door latch for proper adjustment. This is very important especially after the door rope has formed to the stove face.</p> <p>Check door handle for smooth cam operation.</p>

**Note:** These are generic drawings and may not represent your specific model.

# 10 Troubleshooting Guide

With proper installation, operation, and maintenance your woodstove will provide years of trouble-free service. If you do experience a problem, this troubleshooting guide will assist you or a qualified service person in the diagnosis of a problem and the corrective action to be taken.

<b>Start Fire Problems</b>	<b>Possible Cause</b>	<b>Solution</b>
Can not get fire started Excessive smoke or spillage Burns too slowly Not enough heat output	Not enough kindling/paper or no kindling/paper	Use dry kindling, more paper. Arrange kindling & wood for air movement.
	Not enough air for fire to ignite	Check for restricted termination cap
		Check for blockage of outside air kit (if installed).
		Check for flue blockage.
		Pre-warm flue before starting fire (refer to Building a Fire Section).
		Check for adequate vent height (refer to Chimney Height Section).
	Open window below the appliance towards the wind.	
	Wood condition is too wet, too large	Use dry, seasoned wood (refer to Seasoned Wood Section).
	Bed of coals not established before adding wood	Start with paper & kindling to establish bed of coals (refer to Building a Fire Section).
Flue blockage such as birds' nests or leaves in termination cap	Have chimney inspected for creosote and cleaned by a certified chimney sweep.	
Down draft or negative pressure Competition with exhaust devices	Do not use exhaust fans during start-up (refer to Negative Pressure Section).	
	Open window below the appliance towards the wind.	
Fire burns too fast	Extremely dry or soft wood	Mix in hardwood.
		Mix in less seasoned wood after fire is established (refer to Wood Fuel Section).
	Overdrafting	Check for correct vent height; too much vertical height creates overdrafting.
		Check location of vent termination (refer to Chimney Termination Requirement Section).

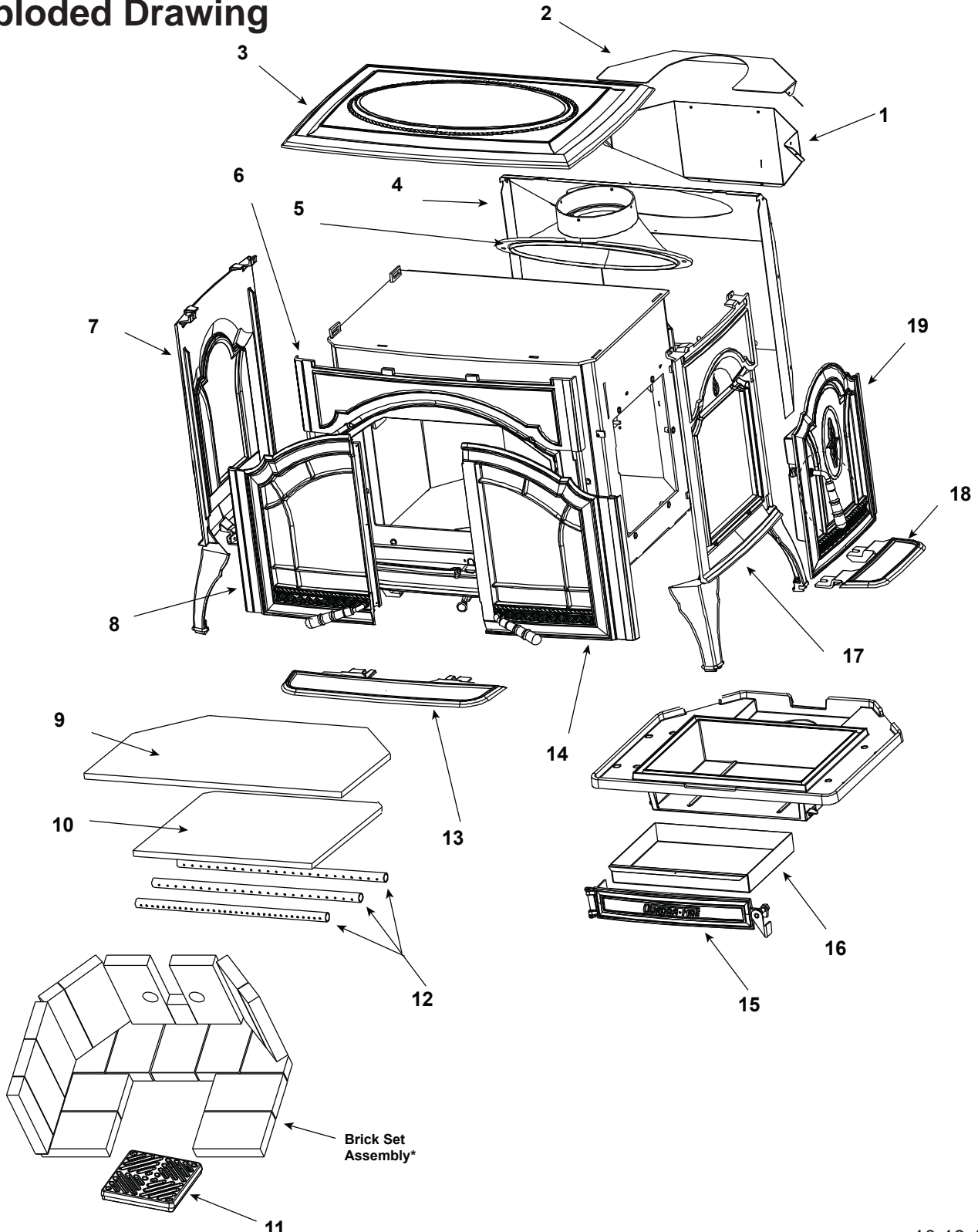
Non-Catalytic, Front/Side Load, Wood Stove

Beginning Manufacturing Date: Jan. 2004

Ending Manufacturing Date: Active

CUMBGAP-MBK (1-04 to Active), CUMBGAP-PMH (1-04 to Active),  
CUMBGAP-PCR (4-04 to 11-06), CUMBGAP-PGR (2-04 to 2-05), CUMBGAP-PMB (2-04 to 7-05)

## Exploded Drawing



Part number list on following page.

10-19-10

IMPORTANT: THIS IS DATED INFORMATION. When requesting service or replacement parts for your appliance please provide model number and serial number. All parts listed in this manual may be ordered from an authorized dealer.



**Stocked  
at Depot**

ITEM	DESCRIPTION	COMMENTS	PART NUMBER	
1	Shield, Flue		7006-171	
2	Flue Shield Top		434-0670	
3	Top - Must Specify color	Matte Black	7006-153MBK	
		Porcelain Mahogany	7006-153POR	
4	Flue Transition Assembly		7006-019	
	Gasket, Rope, 1/4", Field Cut to Size	10 Ft. Length	834-1460	Y
5	Back Shield		7006-131	
6	Face - Must Specify color	Matte Black	7006-223MBK	
		Porcelain Mahogany	7006-223POR	
	Gasket, 7/16", Field Cut to Size (Face & Door)	10 Ft. Length	844-6730	Y
7	Side Left - Must Specify color	Matte Black	7006-152MBK	
		Porcelain Mahogany	7006-152POR	
8	Door Left	Matte Black	7006-155MBK	
		Porcelain Mahogany	7006-155POR	
	Gasket, 7/16", Field Cut to Size (Face & Door)	10 Ft. Length	844-6730	Y
9	Ceramic Fiber Blanket, 1/2" Thick		832-3390	Y
10	Baffle Board		SRV7006-167	Y
11	Ash Grate		7006-211	
12	Manifold Tube Set		TUBES-7006	Y
	Manifold Clip/Screws	Pkg of 4	832-0661	Y
13	Ashlip Front - Must Specify color	Matte Black	7006-156MBK	
		Porcelain Mahogany	7006-156POR	
14	Door Right - Must Specify color	Matte Black	7006-154MBK	
		Porcelain Mahogany	7006-154POR	
15	Ars Door Assembly		7006-008	
	Gasket, Rope, 3/8, Field Cut to Size	10 Ft. Length	SRV7000-134	
	Handle, Ash Removal System		472-5060	
	Nut, Locking Door Handle	Pkg of 24	226-0100/24	Y
	Screw, Pan Head Philips 10-32 X 3/8	Pkg of 40	21799A/40	Y
16	Ars Pan		7006-163	
17	Side Right - Must Specify color	Matte Black	7006-151MBK	
		Porcelain Mahogany	7006-151POR	
18	Ashlip Side - Must Specify color	Matte Black	7006-157MBK	
		Porcelain Mahogany	7006-157POR	

Additional service part numbers appear on following page.

IMPORTANT: THIS IS DATED INFORMATION. When requesting service or replacement parts for your appliance please provide model number and serial number. All parts listed in this manual may be ordered from an authorized dealer.



**Stocked  
at Depot**

ITEM	DESCRIPTION	COMMENTS	PART NUMBER	
19	Side Door Assembly - Must specify color	Matte Black	7006-031MBK	
		Porcelain Mahogany	7006-031PMH	
	Bracket, Door Lock		7006-198	
	Fiber Handle		SRV433-1380	Y
	Gasket, Door, 1/2", Field Cut to Size	10 Ft.	834-4170	Y
	Screw, Flat Head Philips 8-32 x 1/2	Pkg of 10	832-0860	
	Screw, Pan Head Philips 8-32 x 3/8	Pkg of 40	225-0500/40	Y
	Side Door - Must specify color	Matte Black	7006-225MBK	
		Porcelain Mahogany	7006-225POR	
	Side Door Handle, Gold		7006-037	
	Side Door Shield		SRV7006-212	
	Door Handle, <b>Left</b>	Gold	7006-036	
		Nickel	7006-039	
	Door Handle, <b>Right</b>	Gold	7006-035	
		Nickel	7006-038	
	Side Door Latch Bracket		7006-198	
<p><b>#20 Brick Set</b></p>				
20	Brick Assembly - Complete Set	Pkg of 19	BRICK-7006	
20.1	Brick, 9" x 4-1/2" x 1-1/4"	Qty. 4 Req.		
20.2	Brick, 9" x 4-1/2" x 1-1/4" w/Hole (see diagram)	Qty. 2 Req.	SRV436-0380	Y
20.3	Brick, 9" x 2-1/4" x 1-1/4"	Qty. 2 Req.		
20.4	Brick, 3" x 2-1/4" x 1-1/4"	Qty. 1 Req.		
20.5	Brick, 6-3/4" x 4-1/2"	Qty. 7 Req.		
20.6	Brick, 6-1/2" x 4-1/4" angled (see diagram)	Qty. 2 Req.		
20.7	Brick, 9" x 2" x 1-1/4"	Qty. 1 Req.		
	Brick, Uncut ( <b>Must specify size when ordering</b> )	Pkg of 1	832-0550	
		Pkg of 6	832-3040	

Additional service part numbers appear on following page.



IMPORTANT: THIS IS DATED INFORMATION. When requesting service or replacement parts for your appliance please provide model number and serial number. All parts listed in this manual may be ordered from an authorized dealer.



**Stocked  
at Depot**

ITEM	DESCRIPTION	COMMENTS	PART NUMBER	
	Component Pack (Includes Baffle Diverter and Instructions, 2 Leg Leveling Nuts & 2 Bolts, Touch-Up Paint, Owners Manual & Warranty Card)	Matte Black	7006-026	
		Porcelain Mahogany	7006-044	
	Diverter, Baffle - <b>Required on all Horizontal Installations</b>	7006-201		
	Leveling Assembly		7000-000	
	Paint Touch-Up	Matte Black	812-0910	
		Porcelain Mahogany	855-1450	Y
	Glass Assembly		7006-045	Y
	Gasket, Rope, 1/4", Field Cut to Size	10 Ft. Length	834-1460	Y
	Glass Tabs	Pkg of 12	832-0380	
	Knob	Pkg of 2	32284/2	Y
	Latch Ars		7004-160	
	Latch Block, Door		7006-203	
	Latch, Magnet		229-0631	
	Side Door Hinge Assembly		7006-047	
	Speed Control Only (Rheostat)		842-0370	Y
<b>ACCESSORIES</b>				
	Blower Assembly		831-1701	
	Firescreen		SCR-7006	
	Screen Handle		480-1320	
	Horizontal Heat Shield - Required on all Horizontal Installations		HTSHLD-7006	Y
	Outside Air Kit		831-1780	
	Front Cover		436-7000	
	Outside Air Collar Assembly		7033-039	
	Outside Air Shield		33271	Y
	Rear Channel		436-7020	
	Rear Cover Plate		436-7030	
	Side Channels		436-7010	
<b>FASTENERS</b>				
	Avk Rivnut Repair Kit - 1/4-20 & 3/8-16 Rivnut Tools		RIVNUT-REPAIR	Y
	Bolt, Hex Head, 1/4-20 X 1	Pkg of 10	25221A/10	Y
	Nut, Locking Door Handle	Pkg of 24	226-0100/24	Y
	Nut, Ser Flange Small 1/4-20	Pkg of 24	226-0130/24	Y
	Screw, Flat Head Philips 8-32 X 1/2	Pkg of 10	832-0860	Y
	Screw, Pan Head Philips 10-32 X 3/8	Pkg of 40	21799A/40	Y
	Screw, Pan Head Philips 8-32 X 3/4	Pkg of 24	229-1100/24	Y
	Screw, Pan Head Philips 8-32 X 3/8	Pkg of 40	225-0500/40	Y
	Screw, Sheet Metal #8 X 1/2 S-Grip	Pkg of 40	12460/40	Y

**C. Warranty Policy**

**Hearth & Home Technologies Inc.  
LIMITED LIFETIME WARRANTY**

Hearth & Home Technologies Inc., on behalf of its hearth brands ("HHT"), extends the following warranty for HHT gas, wood, pellet, coal and electric hearth appliances that are purchased from an HHT authorized dealer.

**WARRANTY COVERAGE:**

HHT warrants to the original owner of the HHT appliance at the site of installation, and to any transferee taking ownership of the appliance at the site of installation within two years following the date of original purchase, that the HHT appliance will be free from defects in materials and workmanship at the time of manufacture. After installation, if covered components manufactured by HHT are found to be defective in materials or workmanship during the applicable warranty period, HHT will, at its option, repair or replace the covered components. HHT, at its own discretion, may fully discharge all of its obligations under such warranties by replacing the product itself or refunding the verified purchase price of the product itself. The maximum amount recoverable under this warranty is limited to the purchase price of the product. This warranty is subject to conditions, exclusions and limitations as described below.

**WARRANTY PERIOD:**

Warranty coverage begins on the date of installation. In the case of new home construction, warranty coverage begins on the date of first occupancy of the dwelling or six months after the sale of the product by an independent, authorized HHT dealer/ distributor, whichever occurs earlier. The warranty shall commence no later than 24 months following the date of product shipment from HHT, regardless of the installation or occupancy date. The warranty period for parts and labor for covered components is produced in the following table.

The term "Limited Lifetime" in the table below is defined as: 20 years from the beginning date of warranty coverage for gas appliances, and 10 years from the beginning date of warranty coverage for wood, pellet, and coal appliances. These time periods reflect the minimum expected useful lives of the designated components under normal operating conditions.

Warranty Period		HHT Manufactured Appliances and Venting							Components Covered
Parts	Labor	Gas	Wood	Pellet	EPA Wood	Coal	Electric	Venting	
1 Year		X	X	X	X	X	X	X	All parts and material except as covered by Conditions, Exclusions, and Limitations listed
2 years				X	X	X			Igniters, electronic components, and glass
		X	X	X	X	X			Factory-installed blowers
				X					Molded refractory panels
3 years				X					Firepots and burnpots
5 years	1 year			X	X				Castings and baffles
7 years	3 years		X	X	X				Manifold tubes, HHT chimney and termination
10 years	1 year	X							Burners, logs and refractory
Limited Lifetime	3 years	X	X	X	X	X			Firebox and heat exchanger
90 Days		X	X	X	X	X	X	X	All replacement parts beyond warranty period

See conditions, exclusions, and limitations on next page.

**WARRANTY CONDITIONS:**

- This warranty only covers HHT appliances that are purchased through an HHT authorized dealer or distributor. A list of HHT authorized dealers is available on the HHT branded websites.
- This warranty is only valid while the HHT appliance remains at the site of original installation.
- Contact your installing dealer for warranty service. If the installing dealer is unable to provide necessary parts, contact the nearest HHT authorized dealer or supplier. Additional service fees may apply if you are seeking warranty service from a dealer other than the dealer from whom you originally purchased the product.
- Check with your dealer in advance for any costs to you when arranging a warranty call. Travel and shipping charges for parts are not covered by this warranty.

**WARRANTY EXCLUSIONS:**

This warranty does not cover the following:

- Changes in surface finishes as a result of normal use. As a heating appliance, some changes in color of interior and exterior surface finishes may occur. This is not a flaw and is not covered under warranty.
- Damage to printed, plated, or enameled surfaces caused by fingerprints, accidents, misuse, scratches, melted items, or other external sources and residues left on the plated surfaces from the use of abrasive cleaners or polishes.
- Repair or replacement of parts that are subject to normal wear and tear during the warranty period. These parts include: paint, wood, pellet and coal gaskets; firebricks; grates; flame guides; and the discoloration of glass.
- Minor expansion, contraction, or movement of certain parts causing noise. These conditions are normal and complaints related to this noise are not covered by this warranty.
- Damages resulting from: (1) failure to install, operate, or maintain the appliance in accordance with the installation instructions, operating instructions, and listing agent identification label furnished with the appliance; (2) failure to install the appliance in accordance with local building codes; (3) shipping or improper handling; (4) improper operation, abuse, misuse, continued operation with damaged, corroded or failed components, accident, or improperly/incorrectly performed repairs; (5) environmental conditions, inadequate ventilation, negative pressure, or drafting caused by tightly sealed constructions, insufficient make-up air supply, or handling devices such as exhaust fans or forced air furnaces or other such causes; (6) use of fuels other than those specified in the operating instructions; (7) installation or use of components not supplied with the appliance or any other components not expressly authorized and approved by HHT; (8) modification of the appliance not expressly authorized and approved by HHT in writing; and/or (9) interruptions or fluctuations of electrical power supply to the appliance.
- Non-HHT venting components, hearth components or other accessories used in conjunction with the appliance.
- Any part of a pre-existing fireplace system in which an insert or a decorative gas appliance is installed.
- HHT's obligation under this warranty does not extend to the appliance's capability to heat the desired space. Information is provided to assist the consumer and the dealer in selecting the proper appliance for the application. Consideration must be given to appliance location and configuration, environmental conditions, insulation and air tightness of the structure.

**This warranty is void if:**

- The appliance has been over-fired or operated in atmospheres contaminated by chlorine, fluorine, or other damaging chemicals. Over-firing can be identified by, but not limited to, warped plates or tubes, rust colored cast iron, bubbling, cracking and discoloration of steel or enamel finishes.
- The appliance is subjected to prolonged periods of dampness or condensation.
- There is any damage to the appliance or other components due to water or weather damage which is the result of, but not limited to, improper chimney or venting installation.

**LIMITATIONS OF LIABILITY:**

- The owner's exclusive remedy and HHT's sole obligation under this warranty, under any other warranty, express or implied, or in contract, tort or otherwise, shall be limited to replacement, repair, or refund, as specified above. In no event will HHT be liable for any incidental or consequential damages caused by defects in the appliance. Some states do not allow exclusions or limitation of incidental or consequential damages, so these limitations may not apply to you. This warranty gives you specific rights; you may also have other rights, which vary from state to state. EXCEPT TO THE EXTENT PROVIDED BY LAW, HHT MAKES NO EXPRESS WARRANTIES OTHER THAN THE WARRANTY SPECIFIED HEREIN. THE DURATION OF ANY IMPLIED WARRANTY IS LIMITED TO DURATION OF THE EXPRESSED WARRANTY SPECIFIED ABOVE.

# QUADRA-FIRE®

## CONTACT INFORMATION:

Hearth & Home Technologies  
1445 North Highway  
Colville, WA 99114  
Division of HNI INDUSTRIES

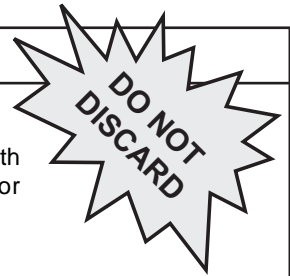
Please contact your Quadra-Fire dealer with any questions or concerns.  
For the number of your nearest Quadra-Fire dealer,  
log onto [www.quadrafire.com](http://www.quadrafire.com)

### CAUTION



#### DO NOT DISCARD THIS MANUAL

- Important operating and maintenance instructions included.
- Read, understand and follow these instructions for safe installation and operation.
- Leave this manual with party responsible for use and operation.



We recommend that you record the following pertinent information for your CUMBERLAND GAP WOOD STOVE

Date purchased/installed: \_\_\_\_\_

Serial Number: \_\_\_\_\_ Location on appliance: \_\_\_\_\_

Dealership purchased from: \_\_\_\_\_ Dealer phone: \_\_\_\_\_

Notes: \_\_\_\_\_

\_\_\_\_\_

\_\_\_\_\_

This product may be covered by one or more of the following patents: (United States) 5341794, 5263471, 6688302, 7216645, 7047962 or other U.S. and foreign patents pending.

